



Endorsed By



---

RUGBY  
LEAGUE  
COACHING  
MANUALS

---

Since 1993

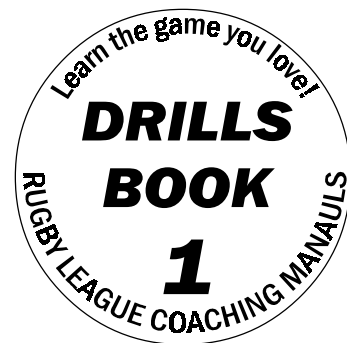

# DRILLS BOOK (1)

## CONTENTS

**91**  
*Drills*

- 2 Ruck Drills
- 6 Training Games
- 8 Kicking Drills
- 13 Defence & Tackling Drills
- 19 Attacking Drills

### RLCM Coaching Books

#### QUEENSLAND

Suite 1F, Trust House, 3070 Gold Coast Hwy, Surfers Paradise QLD. AUST.4217  
Tel: 07 5538 9377, Fax: 07 5538 9388

#### NEW SOUTH WALES

Suite 111 - 353 King Street, Newtown NSW. AUST. 2042  
Phone: 1 800 18 14 14, Fax: 1800 18 14 15

#### UNITED KINGDOM

The Conifers, New Lane, Skelmanthorpe, Huddersfield, West Yorkshire UK HD8 9EH  
Email: engalnd@rlcm.com.au

#### NEW ZEALAND

132 Victoria Road, St Kilda, Dunedin, New Zealand  
Fax (03) 456 3498, Email: rlcm@ihug.co.nz

# Drills

## PLAY THE BALL (Fours)

Endorsed By



RUGBY  
LEAGUE  
COACHING  
MANUALS

Since 1993

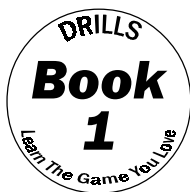

- Ruck Drills
- Training Games
- Kicking Drills
- Defence & Tackling Drills
- Attacking Drills



www.rlcm.com.au

QUEENSLAND  
Suite 1F First Floor Trust House  
3070 Gold Coast Hwy  
Surfers Paradise QLD Aust 4217  
Tel: 07 5538 9377 Fax: 07 5538 9388

NEW SOUTH WALES  
Suite 111 - 353 King Street  
Newtown NSW Aust 2042  
Tel: 1800 18 14 14  
Fax: 1800 18 14 15

UNITED KINGDOM  
Conifers, Hew Lane,  
Skelmanthorpe, Huddersfield  
West Yorkshire UK HD8 9EH  
Email: rlcm@rlcm.com.au

SETTING: Open Space  
Groups of four players  
1 football per group

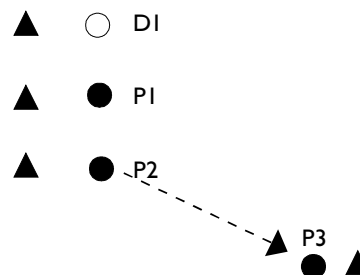

**GUIDELINES:**

Player 1 plays the ball to P2 the acting half back. P2 passes to P3. D1 is the defence marker.

Rotate the position of each player after each play the ball.

Ensure proper technique in the play the ball.

Marker can apply pressure to the play the ball.

Player playing the ball should start from a tackled position on the ground.

**COACHING POINTS**

1. Tackled player (P1) to regain feet as quickly as possible.
2. Football held securely.
3. Football placed on ground correctly.
4. Control of football with the foot.
5. Good even roll of the ball back with foot.

Ruck

## MARKER DEFENCE FOUR ON TWO

## MARKER DEFENCE FOUR ON THREE

Setting: - Channel 10 x 20m, 6 players,  
2 players are defenders, 4 are attackers.

Setting: - Channel 10 x 20m, 7 players,  
3 players are defenders, 4 are attackers.

- Play the ball occurs in centre track
- The ball is returned to the centre after each ruck.
- The marker must chase to the receiver while the other holds to protect the middle.
- Rotate roles
- Attackers can vary their width and the dummy half can also run to challenge the middle

- Play the ball as in four on two
- Include D3, no wraps or reverse passes for attack but players can use inside balls and dummy half runs to challenge the holding marker
- Forces D2 and D3 to adjust to A2 and A3 while D1 controls the the middle.

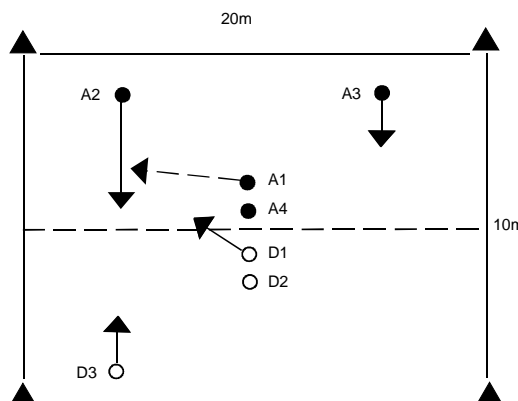
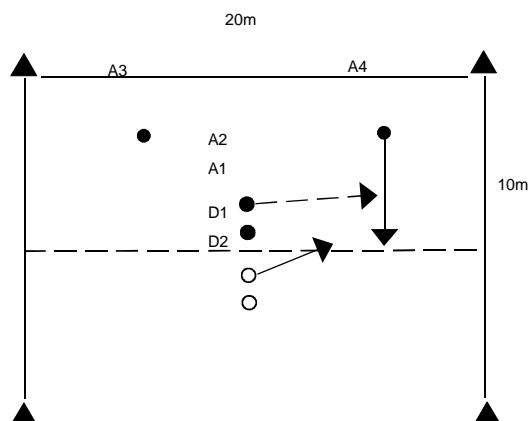

Ruck

Ruck

# MARKER DEFENCE FOUR ON FOUR

Setting: - Channel 10 x 20m, 8 players,  
4 players are defenders, 4 are attackers.

- Play the ball as in previous drills
- Introduce D4
- 'A' players can use all options in attack.
- Tight spot defenders must move forward to the advantage line and nominate in defence.

EMPHASISE: Communication, nomination, one marker holds and one chases, chase must be over the advantage line.

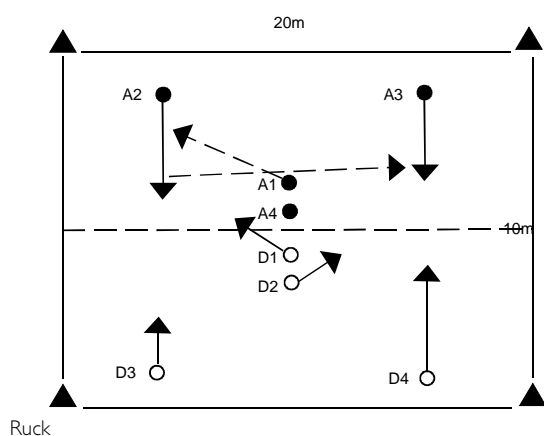

Ruck

# ROLL/PLAY THE BALL DRILL

Setting - Players form two teams 15m apart opposite each other.

On coaches command

- P1 from the Blue Team rolls the ball along the ground towards a member of the Gold Team.
- Player B who falls on the ball securely, plays the ball correctly to Player A. Each of the other members of the Gold Team form a backline; the ball is passed from player A to C, D, E, then F.
- Player F, upon reaching the marker, rolls the ball towards any member of the Blue Team.
- Once retrieved, the ball is played correctly with another member of the team moving into acting halfback.
- All other players position themselves in a backline formation and continue the drill along the same lines as the Gold Team.

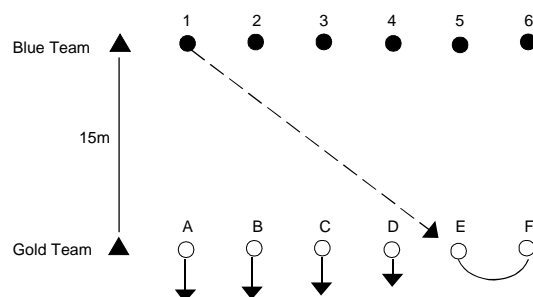

Ruck

# ROUND ROBIN PLAY THE BALL

- P1 who is positioned on the ground, rises to his feet and plays the ball to P2 who is directly behind him (acting half back).
- P2 passes left to P3 who falls to the ground and raises to his feet to play the ball to P4.
- P4 passes right to P5 who falls to the ground and then raises to his feet to play the ball to P6
- P6 passes left to P7 who falls to the ground and then raises to his feet to play the ball to P8.
- P8 runs to the position held by P1 initially.
- Each player, having completed his role moves to the position taken up by the next player in the drill.
- The drill is performed until P1 is back in his original position.

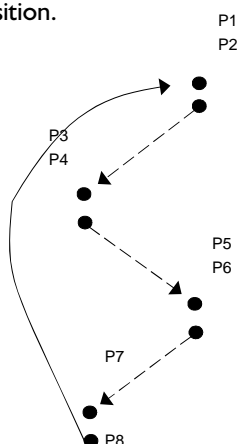

Ruck

# SQUARE DRILL

Setting: - Grid 7m x 7m

- P1 plays the ball to P2 who passes to P3
- P3 drops to the ground, regains his feet quickly and plays the ball to P1 who has taken his position behind P3, having run in a straight line to become acting half back.
- P1 then passes the ball to P4 who repeats the activity of P3, who now assumes the role of acting half back.
- This procedure is repeated for a period of time.
- The drill may be used competitively by allocating one point for each play the ball performed correctly.

Three or four grids may be used competitively for further enjoyment.

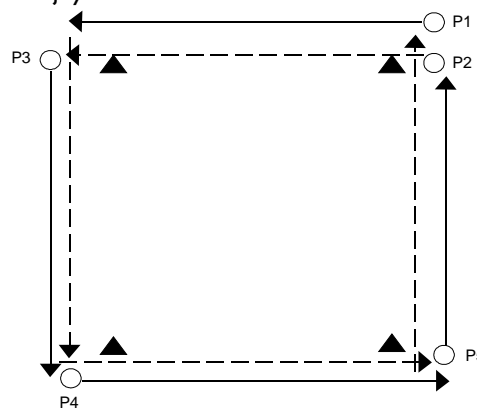

Ruck

Rugby League Coaching Manuals (RLCM)  
**SNAKES & LADDERS**  
 (TECHNIQUE)

SETTING: Grid 15m X 5m  
 8 Markers  
 5 Players  
 1 Football

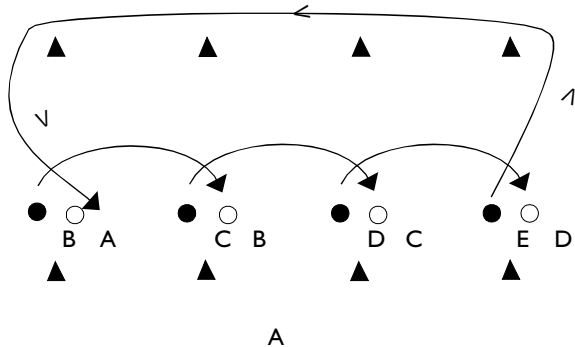

**GUIDELINES:**

- Player A starts and plays the ball to player B.
- Player B runs out and around in front of player C. Player B then plays the ball.
- Player C then runs out and around in front of player D. Player C then plays the ball.
- Player D then runs out and around in front of player E. Player D then plays the ball.
- Player E then runs around the side of the grid and runs out and around in front of player A. Player E then plays the ball to player A who begins the routine again.

Ruck

**PLAY THE BALL RELAY**

SETTING:  
 2 Markers  
 4 Players  
 1 Football

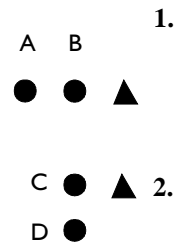

**GUIDELINES:**

- Distance between markers 1 - 2 metres
  - Player A plays the ball to player B.
  - Player B passes the ball off the ground to player C.
  - Player A runs behind player D.
  - Player C passes (standing) the ball back to player B.
  - Player B keeps ball and moves to player A's original position.
  - Player c runs to marker and takes up player B's original position.
  - Drill is repeated involving player B, C and D and so on...
- N.B. Change drill so that players are passing left to right. No 'baby passes'.

Ruck

Rugby League Coaching Manuals (RLCM)  
**WARM-UP HANDLING DRILL**

SETTING: Grid 10m X 10m  
 4 Groups of players  
 1 - 2 Footballs

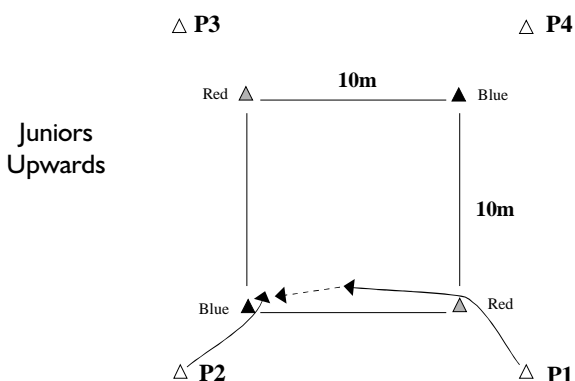

**VARIOUS BALL HANDLING EXERCISES**

Start

1. Player from group 1 commences running and passes off to P2 who times run from marker to accept an onside pass from P1, P2 - P3, P3 - P4 etc.
2. Inside pass at each corner.
3. On blue markers ball placed on ground, then picked up from ground by blue marker player and passed off at red marker.

VARIATIONS: i) Introduce 2 footballs  
 ii) Change direction of run

Game

**GREAT VALUE**

RLCM 1-29  
 Drills Books 1 & 2  
 Coach Talk 1 & 2  
 Junior Coaching 1

Receive All  
 RLCM Books  
 Produced as at  
 March 2003

By purchasing the RLCM CD you will be able to easily distribute coaching information to all coaches within your club, print multiple copies or single stories, save to disk, email to other coaches and assure this valuable coaching information will remain as a reference for future coaches of the club.

Order your CD Now

www.rlcm.com.au



RUGBY  
 LEAGUE  
 COACHING  
 MANUALS

Since 1993

**Drills**  
 BOOK



COACH  
 Talk  
 YEARBOOK

# TAG GRIDIRON

SETTING: · Grid 50m x 30m · 2 Equal teams of players  
· 6 Markers · 1 Football

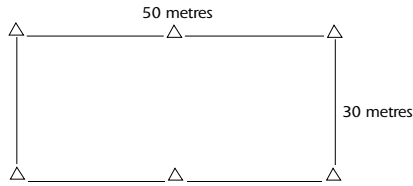

AIM - To score a 'Touchdown' by carrying the ball over the opponents 'Goal Line' or passing it to a team mate who is over the line.

- The game is commenced with a kick off from the middle of the field.
- The attacking team is allowed four 'plays' to score. A 'play' is started with a tap kick.
- All of the attacking team must commence from behind the ball at each play. The first pass must be backward after which off-side play is permitted and forward passes allowed.
- A huddle is permitted for the attacking team, to commence each play.
- Chip and grubber kicking is allowed.
- The defensive team must line up 5 metres in front of the ball.
- A play is complete when the ball carrier has been tagged with two hands, or the ball has been knocked backwards from a pass or kick and regathered.
- The ball need not be recovered on the full, but must not be knocked on. knock-ons regathered from passes or kicks count as one 'play' and the game recommences from where the initial play started.

**BENEFITS OF GAME:**

- Team Work · Communication · Positioning · Passing

Game

# SPEED TOUCH

SETTING: · Grid 20m x 20m (approx. depending on players)  
· 2 Equal teams of players  
· 4 Markers · 1 Football

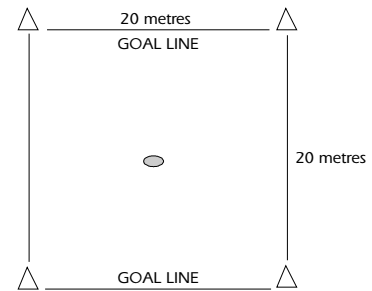

AIM - Team is to score against other team without being touched (one touch per team before hand-over)

- Teams line up on their own goal line to start game
- Ball is placed in middle of grid
- Teams run out and one picks up ball
- Touch can either be a two handed touch, or full tackle
- When the touch is made the ball is placed on the ground and both teams retire to their own goal line and then return to pick up the ball and continue game (hand-over) with a play the ball.
- The team that was attacking now goes on defence.
- Incorrect play the ball incurs a penalty which is a hand-over.
- Other penalties are also a hand-over

**BENEFITS OF GAME:**

- Defence · Passing Skills · Communication
- Decision Making · Fitness

Game

# CHALLENGE

SETTING: · Grid 25m x 35m · 10 players (2 teams of 5)  
· 8 Markers · 1 Football · 5 Bump Pads

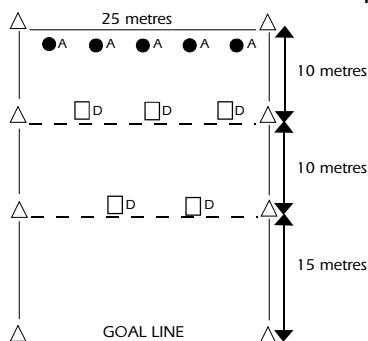

AIM - Five attacking players attempt to score a try against five defenders in two lines, 3 and 2 as per diagram.

- Defenders can only move laterally on their line
- Attackers must use attacking flair and support to first of all get past 3 defenders and then continue to beat the next line of 2 defenders. First 3 defenders can turn and chase when attackers pass their line.
- A tackle is effected by a two handed touch on attackers
- Teams change and alternate attack and defence.
- Points are awarded for tries, and deducted for negative plays that don't advance the attack.

**BENEFITS OF GAME:**

- Communication · Support Play
- Develop Attack and Defence · Decision Making

Game

# TWO BALL LEAGUE

SETTING: · Area 50m x 30m  
· 2 teams of equal numbers  
· 6 Markers · 2 Footballs

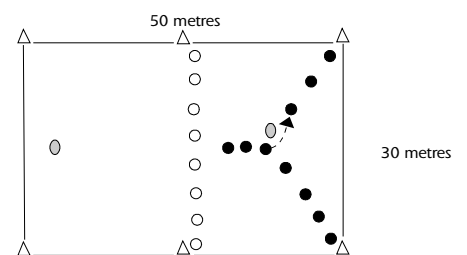

- Rules are identical to the Laws of Rugby League except: No tackling, no kicking, no scrums, two footballs used.
- The major difference in this game is that two footballs are used but only one at a time.
- The game commences as normal with one football while the other ball is placed at one end as displayed.
- The game continues until the coach blows the whistle.
- On this signal, the ball that has been used becomes 'dead' and it must be automatically dropped to the ground.
- The other ball becomes the 'live' ball and the first team to gain possession play on immediately toward their original line.
- There is no pause or stoppage! Teams have to react quickly
- The coach continues to blow his whistle at various times to change footballs.

**BENEFITS OF GAME:**

- Reforming positions · Reaction · Defence
- Communication · Attack - Support play

Game

# BATTLESHIPS

- SETTING:**
- Grid 10m x 10m
  - 2 Equal teams (Passes and Receivers)
  - 4 Markers · 8 Footballs

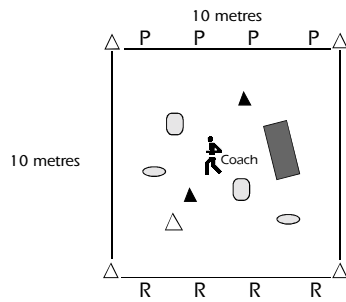

- Place objects inside grid e.g. tackle bag, hit shield, witches hat, marker, football etc.
- Passers line up outside grid, they each complete 4 passes to the right side and four passes to the left.
- 4 players at back of grid (receivers) to act as ball retrievers who pick up ball with two hands, then carry it back and place at passers feet, then return to retrieve the next ball.
- Passers attempt to hit objects, large objects (tackle bags) are removed from grid after being hit 3 times, medium objects (hit shields) removed after 2 hits and smaller objects removed after being hit once.
- Team eliminating most objects wins game.

**VARIATION:** Time limit on passes  
Vary the number of passes

Game

# SPEED ATTACK

- SETTING:**
- Area up to full size field
  - 2 Equal teams of players
  - 2 Footballs

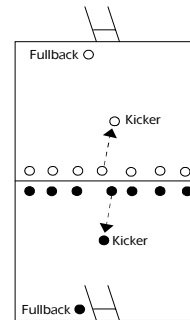

N.B. The ball must not be kicked into touch.

- Two opposing teams line up along halfway. Each team has a kicker and a fullback.
- On a given signal from the coach, the balls are tapped on the ground and passed to the teams kicker who kicks downfield, away from the fullback.
- When the fullback retrieves the ball, he must dive on the ball and wait until all of his team mates are onside before he plays the ball.
- The ball is then played and it must be touched by all players, before reaching halfway.
- The first team to place the ball on halfway scores a point.
- Game can be played to a set time or a number of points.

**BENEFITS OF GAME:**

- Passing · Communication · Fitness

Game

# LEAGUE HAND BALL

- SETTING:**
- Grid 15m x 10m (goal area 3 metres wide)
  - 2 Equal teams of players
  - 10 Markers · 1 Football

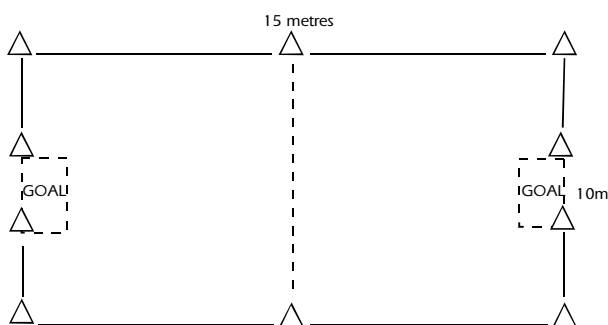

**AIM -** To pass the football between the opponents goal for a point

- Game commences with a kick-off
- Each team is allowed a goal keeper to guard the goal area, but no other players are allowed in this area
- Players may run with the football and pass in any direction
- Opposition players attempt to intercept a pass or knock the ball to the ground to force a change over
- After each point is scored the game recommences with a place kick by the non scoring team

**BENEFITS OF GAME:**

- Passing · Communication
- Decision Making · Space Awareness

Game

# LEAGUE BALL

- SETTING:**
- Grid as per diagram
  - 8 - 10 players per team
  - 1 Football

- The game is played along the lines of Baseball. The batting team can punt kick, grubber kick or drop kick the ball after having it passed to them by the Pitcher. The batter has 2 seconds before he must kick the ball. once three batters are out, the fielding team becomes the batters.
- The ball must be kicked or passed in from the outfield. a fielder cannot run the ball in by himself but two players passing the ball together may run the ball in. Batters on 2, 3 and Home Base must be tagged before they are out.
- On 1st base the baseman must have his foot on the base to run the batter out.
- If the ball lands outside the Diamond on the full, then the batter gets another kick and the players on the bases aren't allowed to run.
- If the ball is caught on the full the player is out and any players between bases must return to the base they were on. They can also be tagged out on the way back to base. (only after a catch)

**BENEFITS OF GAME:**

- Passing · Catching · Kicking · Running

Game

# SCRAMBLE

SETTING: · Grid 25m x 15m · 2 teams of equal numbers  
· 4 Markers · 1 Football

- Players from each team are given a number from 1 to 4.
- Team A - attackers, The coach calls out a number e.g. 4, those players with the number do the following:

### Attackers (Team A)

- All must run to the attacking line and touch the ground with one hand. One of these players picks up the ball. They then run down the corridor attempting to score a try over the line, by staying inside the corridor.

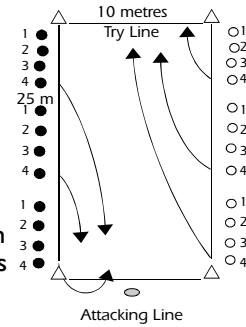

### Defenders (Team B)

- All must run to the try line, touch the ground and run up the corridor preventing Team A scoring a try by two hand tagging or tackling a player in possession.

### Note

- Team A players may pass the ball between themselves but it must not be passed forward.
- Players from each side do not have to wait for all players in their team to get to the line to run. They may go at any time. As soon as players get tagged they return to their position and another number is called.
- 1 point is awarded for a try · Roles are reversed

### BENEFITS OF GAME:

- Communication · Passing · Defence · Attack

Game

# TEN PASSES

SETTING: · Grid 15m x 15m  
· 2 Equal teams of players  
· 4 Markers · 1 Football

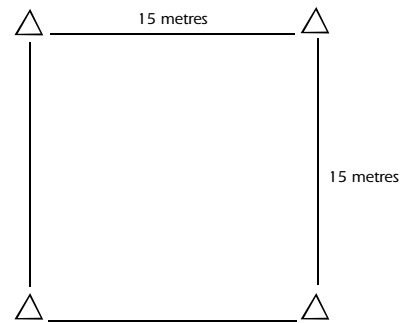

- One team is given the ball and attempts to complete a set of passes (up to 10, nominated by coach)
- Every set completed gains a point
- The opposing team attempts to intercept or knock the ball down, gaining possession when the ball hits the ground or is intercepted
- Player in possession can not move so his team mates must move around to support him and look for the pass
- Passes must be Rugby League style

### BENEFITS OF GAME:

- Passing · Decision Making
- Space Awareness · Communication

Game

# J'OH'S ATTACK

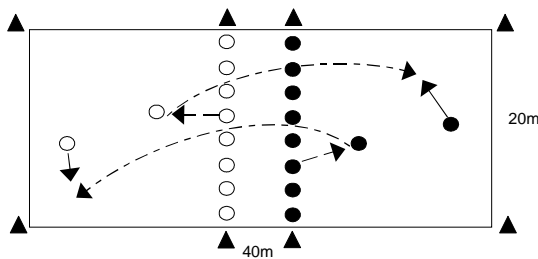

Divide players into two teams.

Two teams line up as indicated and oppose each other along the halfway zone. Each team has a kicker and a fullback and one football.

On the coach's command the balls are tapped on the ground and passed to the team's kicker.

The kicker then kicks the football down field away from the opposing fullback ensuring it lands in the opposition's half. When the ball has landed, all team members run to their line.

The fullback must retrieve the ball by diving on it and then waiting until all of his team are onside before he gets to his feet and joins his team on the line.

The ball is then passed to all players in a backline movement.

The first team to place the ball in the halfway zone wins.

The ball must not be kicked dead, all players except the fullback and kicker start on the line between the hats as indicated. The ball must not be passed forward or knocked on.

Game

# ROB THE NEST

SETTING: · Grid 10m x 10m  
· Even number of players to each corner  
· 4 Markers · 7 or more Footballs

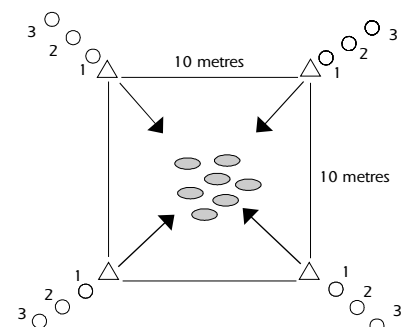

- On command, one player from each team runs into the centre, picks up a ball and places it back at his corner.
- He then tags the next player in his team who repeats
- Player goes to the end of the line
- When all footballs are taken from the centre, players may steal balls from other teams.
- The first team to collect 3 balls at their corner wins.

N.B. Only one player from each team may run into the grid at one time. Only one ball may be taken at any time.

### BENEFITS OF GAME:

- Agility · Handling · Speed & Endurance
- Decision Making

Game

# KICK FAST BREAK

- SETTING:**
- Grid 32m x 15m
  - 2 Equal teams of players (A & B)
  - 8 Markers · 1 Football (more can be used)

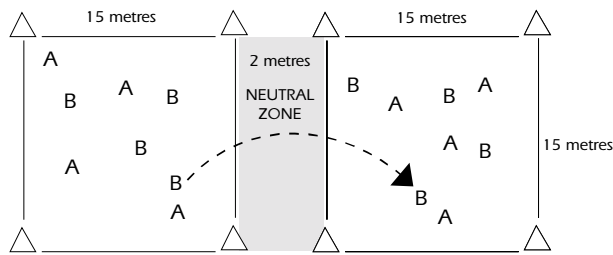

- AIM -** Players to kick football across the neutral zone to a team mate on the other side.
- Teams of players are divided and placed, half of each team is placed on either side of the neutral zone.
  - One point is awarded for every successful kick caught.
  - Opposition players attempt to knock down or intercept the football before it is caught.

**VARIATION:** Kick with non preferred foot  
Catch with one arm

**BENEFITS OF GAME:**

- Kicking technique · Catching
- Communication · Positioning

Kicking

# LEAGUE SOCCER

- SETTING:**
- Grid 20m x 30m
  - 2 Equal teams of players
  - 12 Markers · 1 Football

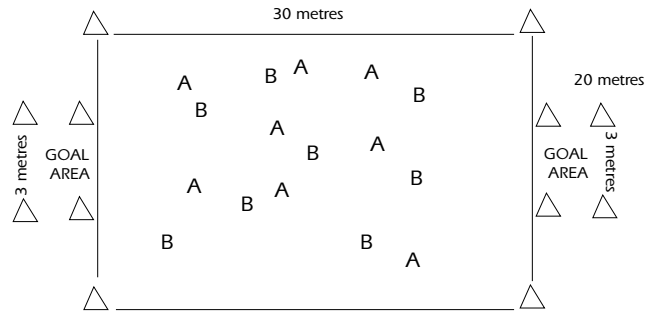

- The game is based on rules of soccer, using a Rugby League football
- Football not to be kicked above shoulder height
- No hands to touch ball (play the ball not the player)
- Goals scored into goal area (3 metres wide)
- Game can be played for a time limit, or nominated number of goals

**BENEFITS OF GAME:**

- Ball Control on ground & dribbling
- Fitness · Communication
- Team Work - co-operation between players

Kicking

# LANES KICKING

- SETTING:**
- Grid 25m x 20m
  - 2 teams of players (4 attackers v 3 defenders)
  - 6 Markers · 1 Football

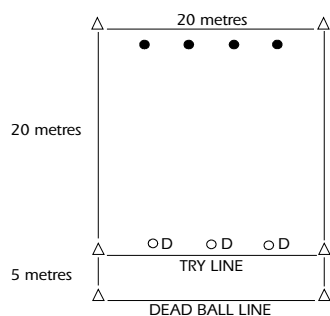

- AIM -** To score tries through kicks
- Attackers have 2 play the balls to score a try.
  - Each play the ball must contain a kick (grubber, chip).
  - Players can run from acting half back position or have one pass (Maximum).
  - Defenders must return to try line after first tackle to commence second play.
  - Competition by awarding a point for each success i.e. score a try to attackers, effect a tackle by defenders.

**VARIATION**

- Able to kick on either 1st or 2nd tackle i.e. run on the first, kick on the second (options)

**BENEFITS OF GAME:**

- Develop competition amongst players · Communication
- Kicking Skills · Decision Making

Kicking

# GOALIE

- SETTING:**
- Grid 25m x 15m
  - Uneven teams e.g. (3 on 2) or (4 on 3)
  - 10 Markers · 1 Football

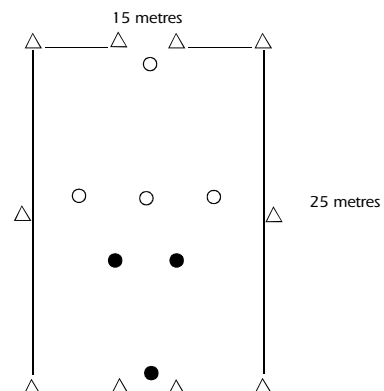

- Each team nominates a goal keeper before play starts.
  - Defending team goal keeper drops back to protect goal.
  - Attacking team passes football amongst themselves, passes can be along ground or Rugby League style and in any direction.
  - Goals are scored by attackers passing or grubber kicking football past goalkeeper and through goals.
  - Change over occurs by dropped ball or two handed touch.
- N.B. -** Defenders take turns as goal keeper

Kicking



# KICK FOR SUPPORT

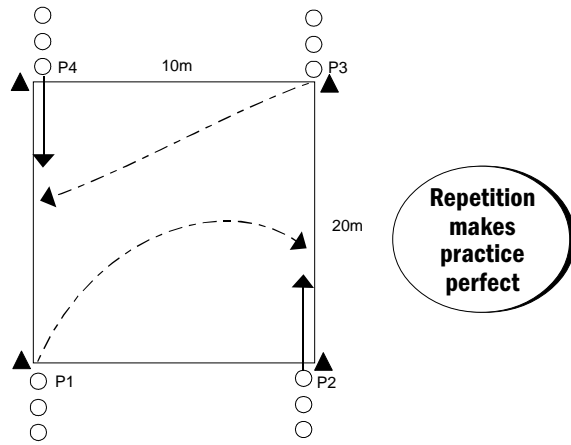

**Aim** Kicking for the support player who cleanly regathers the football.

P1 chip kicks for P2 who regathers on the full and runs through to offload to P3. P3 then grubber kicks for P4 who cleanly regathers the football from the ground and then runs through to offload to P1 who continues the drill.

Once P1 has chip kicked he moves to the end of the line in the P2 position, once P3 has kicked he moves to the end of the line in the P4 position.

As a variation another football can be added to speed the drill up.

Kicking

# GRUBBER BUSTER

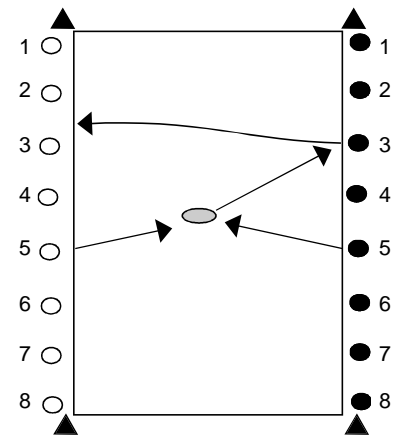

Divide players into 2 teams giving each player a number.

The coach calls out a number and the player from each team with that number runs forward and tries to gain possession of the football in order to return to his team. The successful player recovers the ball from the centre and passes it to any player in his team. That player then must immediately attempt to grubber kick the ball through the other team.

The player unsuccessful of gaining possession can pressure the kicker while his team must attempt to catch the ball by remaining standing on the line. The drill continues until all numbers have been called.

Kicking

# KICK and CHASE

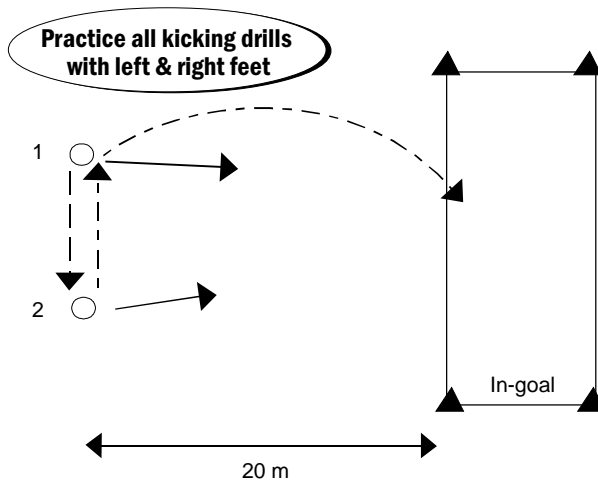

**Aim** To successfully put a kick into the in-goal area, beat a defender to the football and ground the ball to score a try.

Players 1 and 2 pass the ball back and forth. On the coaches command the ball carrier kicks (any nominated kick) to the try line and attempts to score a try by forcing the ball "in goal".

The player without the ball becomes the defender and attempts to tag the other player of "kill" the ball.

Kicking

# NUMBER CATCH

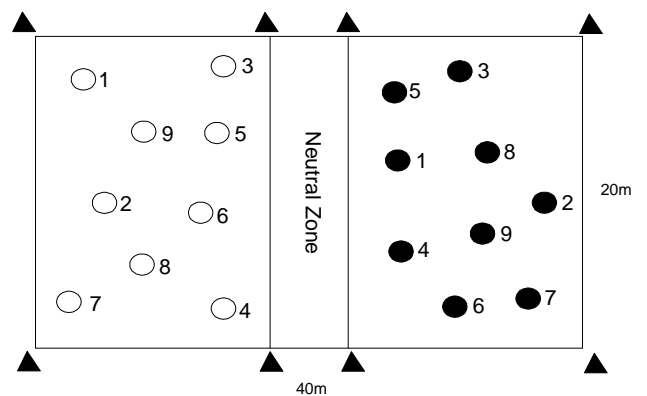

**Aim** For the attacking team to successfully kick across the neutral zone and for the defender to catch the football on the full.

Divide players into two teams. Each player is given a number.

Teams are scattered throughout their own half, as indicated above. The player in possession of the football calls out any number then immediately kicks it over the neutral zone and into the opposition's half. The player with the nominated number must catch the ball. No other player can attempt to catch the ball. Teams must vary their number calls each time they kick.

As a variation another football can be added.

Kicking

# KICK TENNIS

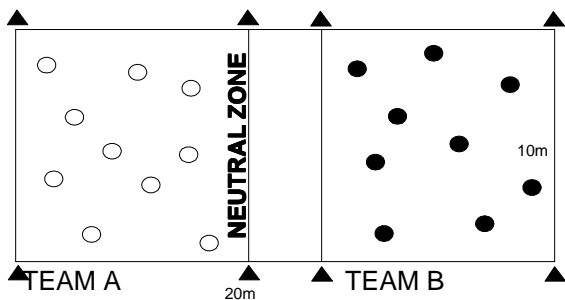

Each team is scattered through their own half as shown in the above diagram.

The ball is kicked by Team A into Team B's half. Their aim is to kick the ball making it land in Team B's half or force an error by a Team B player. If they succeed, a point is scored by Team A. If the ball is caught, no points are awarded. The ball must clear the neutral zone - otherwise possession is forfeited.

The ball is then kicked by Team B and the game continues in 'tennis' fashion. The first team to reach a predetermined score wins.

When the ball is kicked, it must cross the neutral zone at shoulder height or above.

Variations could be, adding two or more footballs. Instead of a scoring system, players making errors are eliminated from the game, the team that loses all its players first loses the game. The player catching the football must pass it to another player who then kicks the football.

Kicking

# CHANNEL KICK

Spent no longer than 10 minutes on each drill

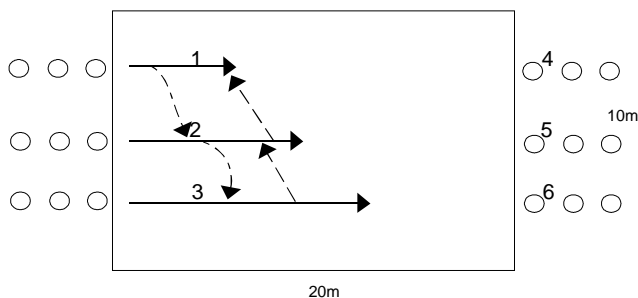

**Aim** Players either kick, catch or recover the football and then pass to support while on the run.

A grid is set up as in the above diagram.

Player 1 runs then grubber kicks to player 2.

Player 2 then chip kicks to player 3.

Player 3 runs then passes to player 2.

Player 2 runs then passes to player 1.

Player 4, 5 and 6 repeat drill. Perform this drill until all players have had an opportunity to grubber, chip and pass.

Kicking

# KICK NETBALL

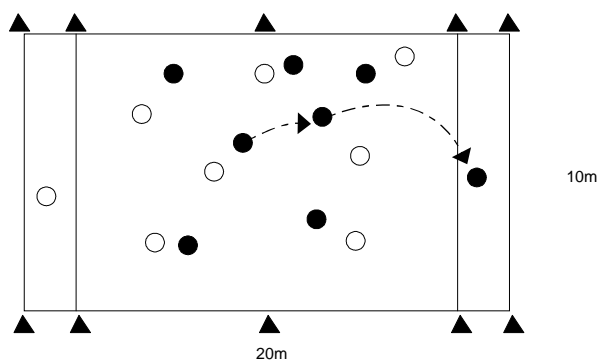

**Aim** For team mates to get the football to the player standing in the in-goal area by kicking the football.

Players are divided into two teams.

Each team kicks the ball between its own members. The ball can be kicked in any direction. The object of the game is to kick the ball to the player who is standing in the oppositions in-goal. Only one player is allowed in the in-goal. If the ball is dropped, the other team gains possession.

Players in possession of the ball must keep their back foot on the ground. Once the ball has been passed he is free to run anywhere in the field. (The game commences at one baseline. There are no set number of kicks needed, play continues if the ball is intercepted.)

Kicking

# GRUBBER OR CHIP THROUGH

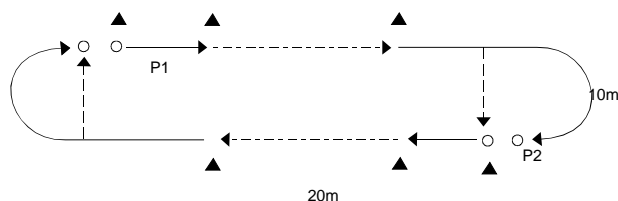

**Aim** Players are to complete a successful kick for themselves, regathering and then passing to support.

P1 runs, grubber kicks through the four witches hats (positioned above), regathers and passes to P2 who repeats back to P3 who continues the drill.

For variation the kick could be chip kick, a defender can be introduced or the kick could be for a partner.



**Enquire about the RLCM CD Coaching Manuals Drills Books and a lot more...**  
www.rlcm.com.au

Kicking

# GRID ISLAND

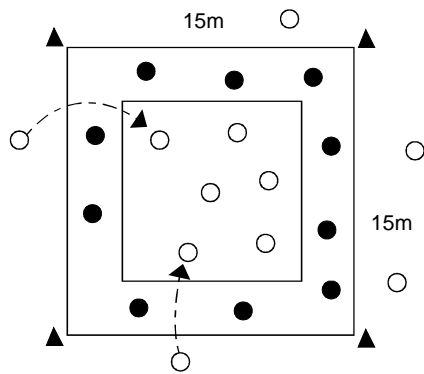

**Aim** Team A players to kick and pass the football to each other without it being intercepted or them being distracted by Team B players.

Divide players into 2 teams.

Two grids are set up as shown (1 small grid inside a large grid).

Team A passes/kicks while Team B are defenders attempting to intercept ball or distract Team A players.

Team A players are divided in to 2 groups, one on the outside of the large grid and one on the inside of small grid.

The outside Team A players start with 4 footballs, on

Kick

GRID ISLAND con't

coache command the players attempt to kick or pass to their team mates in the inside grid. These players must catch the football on the full and must not go outside the small grid. They must then return the ball to the players on the outside of the grid.

Team A players are allowed to run around with the football but must hold the ball for any longer than five seconds. They may also pass the ball to another member of the team who is in a better position.

Team B players are to run around and attempt to intercept or distract team A players.

Once a ball has been dropped it is taken out of play and the drill continues with the remaining balls.

Vary the size of the grid to suit your teams age & ability.

<p><b>RUGBY</b></p> <hr/> <p><b>LEAGUE</b></p> <hr/> <p><b>COACHING</b></p> <hr/> <p><b>MANUALS</b></p> <p><small>Since 1993</small></p>	<p><i>"I believe all clubs and coaches at all levels should have a copy of this magazine as a coaching resource"</i></p> <p><b>WAYNE BENNETT</b></p>	<p>Endorsed By</p> 
<p>• Coaching Manuals • Drills Books • Junior Coaching</p> <p><b>www.rlcm.com.au</b></p>		

Kicking

# DRIBBLE BALL

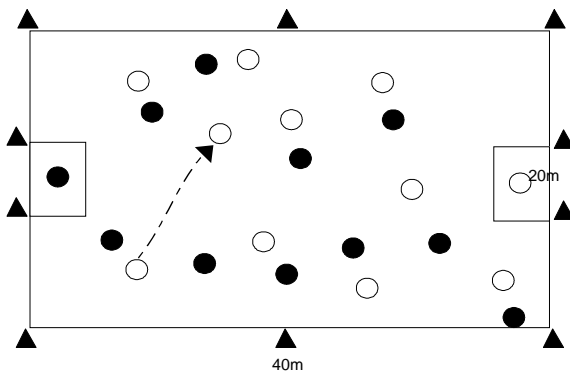

**Aim** To kick the football through the oppositions goal.

Players are divided into 2 teams.

Rules are similar to Soccer but a Rugby League football is used instead. The football is dribbled but players cannot touch the ball with their hands or arms with the exception of the two goal keepers.

Kicking

# KICK and CHASE

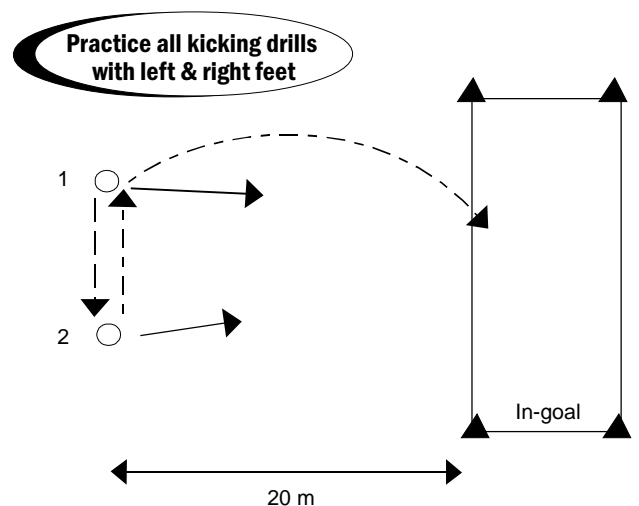

**Aim** To successfully put a kick into the in-goal area, beat a defender to the football and ground the ball to score a try.

Players 1 and 2 pass the ball back and forth. On the coaches command the ball carrier kicks (any nominated kick) to the try line and attempts to score a try by forcing the ball "in goal".

The player without the ball becomes the defender and attempts to tag the other player of "kill" the ball.

Kick

# KICK GOLF

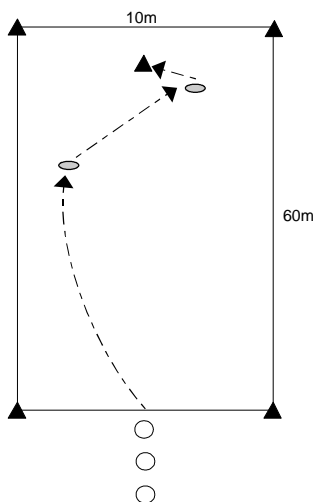

Use your imagination to design a fun kick golf course using any variation of kicks and distances

Players must try to hit the cone placed down field in the least amount of kicks.

The first kick is a punt kick downfield. The second kick is a grubber kick from where the ball has stopped towards the cone. The third kick should be in close enough range for a short stab kick or dribble kick for the ball to hit the cone.

Players keep kicking until they have hit the cone.

Players may need to add another grubber if kicks have gone off target.

Kicking

# TARGET

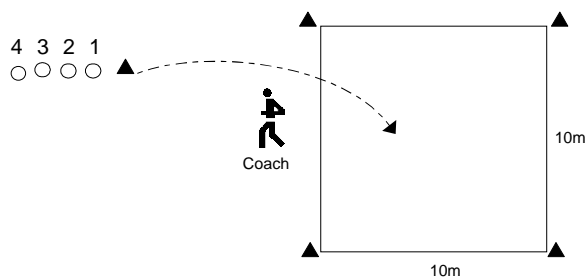

**Aim** To kick the football and have it land in the grid

Each player has a football

**Grubber Kicks**

Players must grubber kick the ball for it to land in the square, 10 metres from the kicking marker.

**Punt Kick**

The grid is taken further away - to 20 metres from the kicking marker. Players punt kick the ball and on the first bounce the ball must bounce in the square.

**Drop / Chip Kick**

As above for the punt kick, however the player / coach is placed between the kicker and the grid. The ball must gain elevation, clearing the coach / player to land in the square on the full.

**Gear Required:** Footballs, Witches Hats

Kicking

# FIND THE GAP

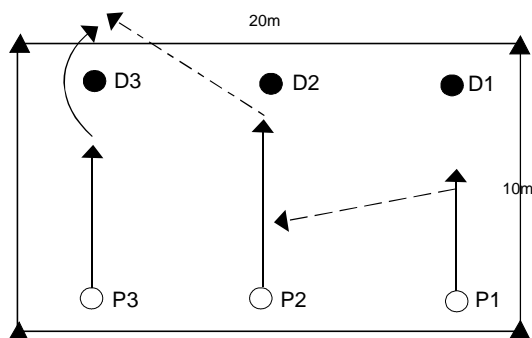

**Aim** To attack the defensive line, grubbering a kick through and the chaser regathers the football behind the line.

Grid is set up as shown in diagram above with players on a three on three situation.

P1 runs out, draws D1 and passes the ball to P2.

P2 runs towards D2 drawing him and then grubber kicking or chip kicking through the gap for P3.

P3 chases and regathers ball

Players must alternate playing positions each time. Drill should be performed from both right and left sides.

Vary the kick between P1, P2 and P3.

Kicking



Learn the game you love!

RUGBY  
LEAGUE  
COACHING  
MANUALS

Since 1993

Endorsed By



# NOMINATION & NUMBERING

- Setting:
- Six attackers and five defenders, five of the attackers will hold hit pads whilst the sixth has a football.
  - Players spread out opposite each other in two lines about 10 metres apart.
- Coach stands behind the defensive line where they cannot see him.
  - He directs the sideways movement of all the attacking players except A1, with the ball, either left or right by pointing.
  - A1 moves at random behind the attacking line.
  - When the coach puts his hand straight up in the air A1 must run forward through the gap in front of him, with the rest of the attacking line moving forward.
  - Defence must adjust to nominate and eliminate all players closest to the ball, thus leaving one attacker on the edge free.
  - Defence must nominate, ball carrier, runner, etc or call by name.

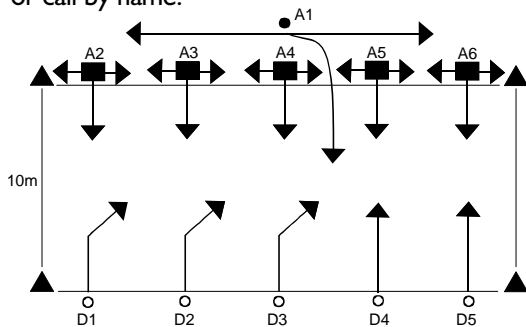

Defence

# DEFEND TWO ON THREE

- Setting:
- Players in a 15 x 10 metre grid
  - Three defenders and four attackers
- A1 and A2 must start within the 5m channel
  - D1 will start 5m from A1 and also within the 5m channel, while D2 and D3 will start 10m away
  - A1 must pass to A2 before A2 is allowed to leave the 5m channel
  - D1 can move as quickly as he wants, however D2 and D3 can only move once D1 has moved
  - the object is to stop the A's from scoring

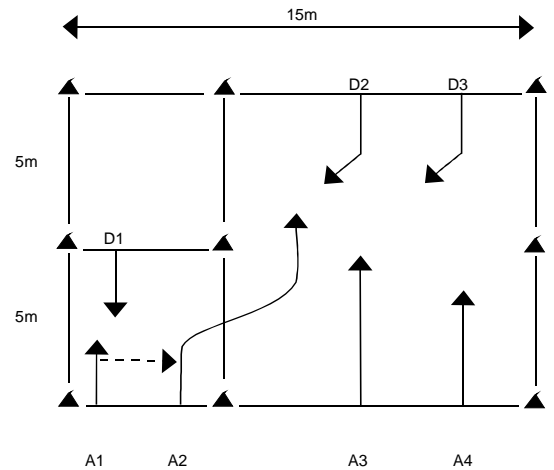

Defence

# SMOTHER DRILL

- Setting:
- Players working in pairs one carrying a hit pad, 5m apart.
- Object is to cover the ball, i.e. pin bump pad to the ATTACKER.
  - Players in pairs, opposite each other and 5 metres distant. Walking Pace.
  - Object is for tackler to cover the ball and or pin the arms of the ball carrier.
  - Defender slightly off-centre of the attacker.
  - The front section of the tackler's shoulder makes contact with the attacker's chest region, shoulders and arms attempting to cover the ball and or pin the arms of the ball carrier.

- Variation
- Increase pace/and or approved distance.
  - Remove pad and add the ball to attack

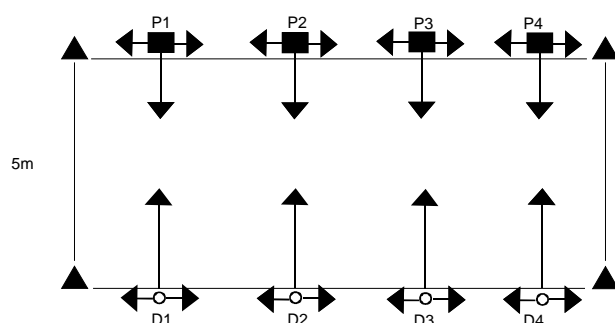

Defence

# FACE-UP DEFENCE

- Setting:
- Corridor 20 x 15m, 4 markers, 12 players, 1 football
- 5 defenders are placed on the base line.
  - 7 attackers are grouped at the opposite end of the grid.
  - The coach kicks the football to the A players.
  - On A players gathering the ball the defenders move forward to prevent A scoring.
- Progression:-
- A & D start with coaches call
  - D move down the grid in formation
  - A follows approx. 10m behind
  - On coaches call, D turns and defends against A who attempts to score.

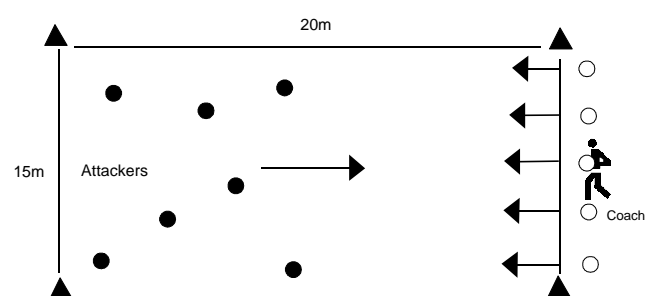

Defence

Rugby League Coaching Manuals (RLCM)  
**BEHIND TACKLE**  
 (TECHNIQUE)

**SIDE ON DEFENCE**  
 (TECHNIQUE)

SETTING: Players in 2 teams  
 Open space distance determined by age group  
 1 Football  
 4 Markers

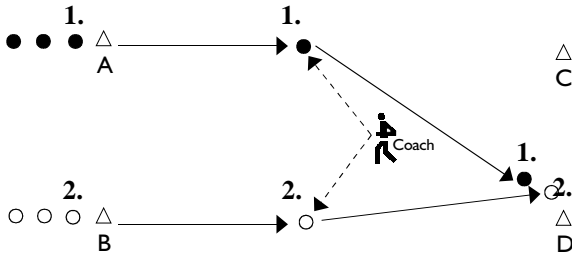

- Players form two equal lines behind markers A and B
- On call players 1 and 2 run in a straight line
- The coach chooses to pass to either player
- The player who receives the ball attempts to score a try between markers C and D
- The defending player attempts to tackle his opposite from behind.

Defence

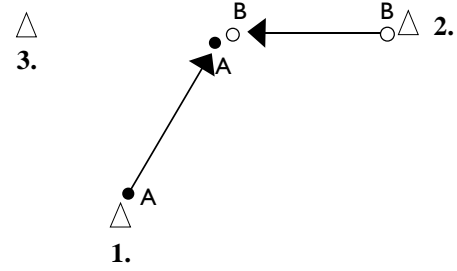

GUIDELINES:

- Player B walks with ball in a direct line from marker 2 to marker 3
- Player A approaches from marker 1 and pushes player B with his left shoulder

N.B. Player A has his arms pointing straight out like an aeroplane and aims to hit the thigh of player B

VARIATION:

- Player B runs from marker 3 to marker 2 so that A uses his right shoulder
- Performed in the same manner as drill A except both player A and B are jogging not walking.
- This time using the same basic drill player A effects a tackle on player B. Both players are jogging.

Defence

Rugby League Coaching Manuals (RLCM)  
**SPRINT & SLIDE**

**THE POSTMAN**

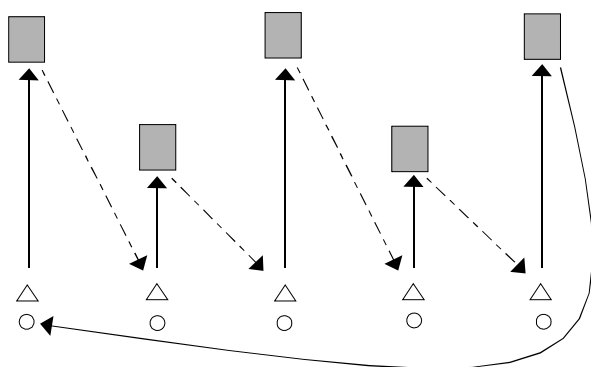

Players are lined up as above. Two tackle bags are positioned 10 metres from two players, whilst three bags are 15 - 20 metres from the other three players.

All players must sprint to the tackle bags and run backwards, shuffling across to the marker. Sprint distances obviously vary in length between 10 metres (short) and 15 - 20 metres (long).

Defence

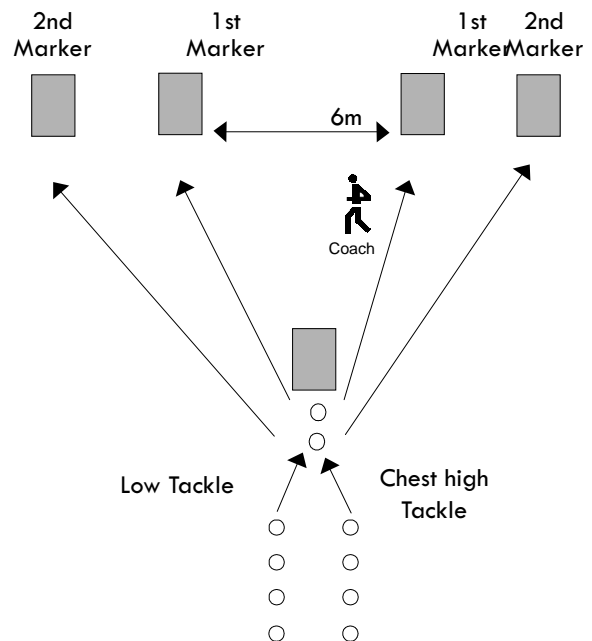

Players perform double tackle on front bag.

The coach rolls a ball to either the left or right markers. The players then chase and tackle the designated tackle bag, opposite the position of the football.

Defence

# REACTION DRILL

Setting: Six lines of players opposite six tackle bags.

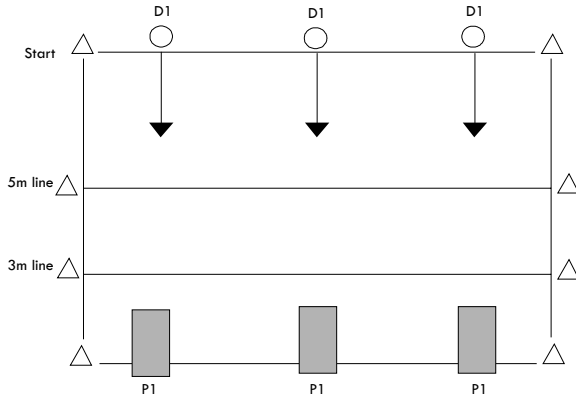

### DRILL

- Player P1 holds bag up in front. He moves bag left or right when the tackler D1 reaches the 5 metre mark.

### VARIATION

- Reduce distance ie 5 metres to 3 metres etc

Defence

# LAST 15 DEFENCE DRILL

Setting: Seven attackers on four defenders, grid 40m x 20m

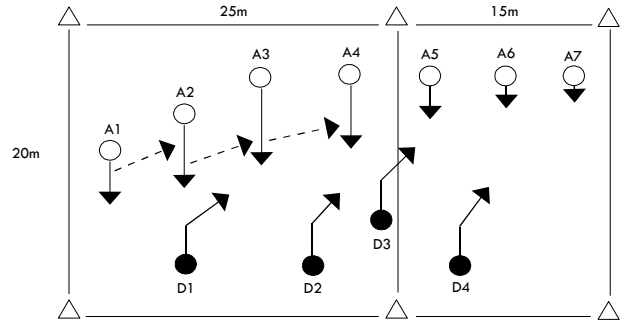

### DRILL

- Attackers attempt to score within the last 15m width of the field.
- Defence must show the edge to the attackers
- Last two defenders should work to shutdown the last four attackers on the edge.
- The remaining two defenders should work in cover to ensure no inside balls are successful

Defence

# SITUATIONAL DEFENCE

Setting Next 4 Drills:

Small groups of players work in 10m x 10m grids - The defence's role, after the ball has passed his opposite, is to take the inside position on the next, outside attacker (this can not occur under a wedging system)

(a) Against Run Around

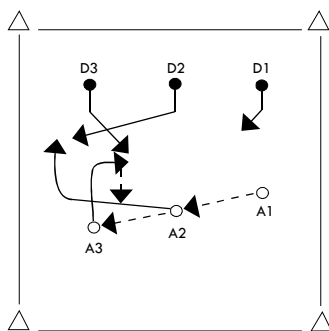

6  
players  
3  
attackers  
3  
defenders

### DRILL

- A2 around A3
- D3 takes A3
- D2 follows A2
- D1 fills in

### ALTERNATIVE

- A2 around A3
- D2 communicates to D3 to take out A2
- D2 takes A3
- D1 fills in

Also use A1 around A3

Defence

# SITUATIONAL DEFENCE

(b) Against Reverse Pass (see run around)

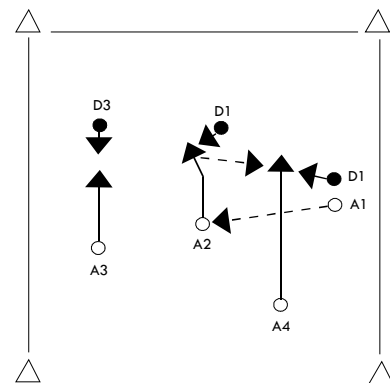

7 players - 4 attackers and 3 defenders

### DRILL

- A1 passes to A2
- A2 moves across field
- A2 REVERSES to A4
- D1 fills in

### ALTERNATIVE

- A1 passes to A2 onto A3
- A2 around A3
- A3 REVERSES to A4
- D3 stays with A2 (or A3)
- D3 takes A3
- D1 fills in on A4

Defence

(c) Against Scissor (angle)

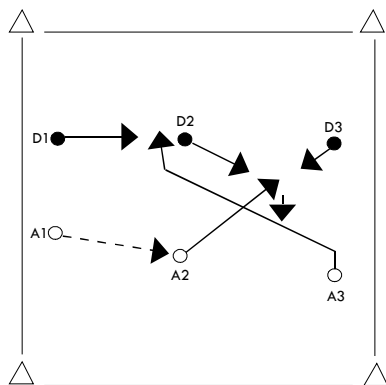

6 players - 3 attackers and 3 defenders

**DRILL**

- A1 passes to A2
- Attacker (A2) drags D2 across toward D3
- Attacker (A3) moves inside A2 when A2 commences to draw D3
- A3 is taken by the Cover D1 or D3

Defence

**SITUATIONAL DEFENCE**

(d) Against Extra Man

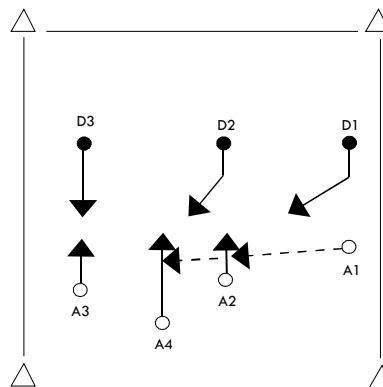

7 players - 4 attackers and 3 defenders

**DRILL**

- A1 passes to A2
- D2 and D3 move up
- A2 passes to A4
- D2 must move up and out
- D1 (or inside man) takes A2

Defence

Rugby League Coaching Manuals (RLCM)  
**NUMBERS TACKLING**

Divide your team into two equal groups, generally forwards and backs. One group holds the tackle bags or pads, the other group form up in a circle inside and facing the bags. The bag that they are facing is their number 0 bag. *In this diagram we are showing how the circle looks to tackler number 1.*

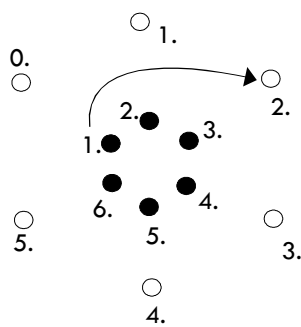

**Coaches Command  
 "2 Right"**

The coach calls commands such as "1 right", the players all have to move one bag to their right and tackle that bag. Then they move directly back and that bag then becomes their new 0 bag. The coach may then call "2 left" and the players move two bags to the left and make the tackle. Then move directly back with the bag tackled their new 0 bag.

Players must remember that once they move directly back, the bag just tackled becomes their new number 0 bag. It changes with each tackle. The players keep tackling until one or more players gets it wrong, they then pay a penalty (20 metre sprint) and they change roles with bag holders.

Defence

**DOUBLE ZONE TAG**

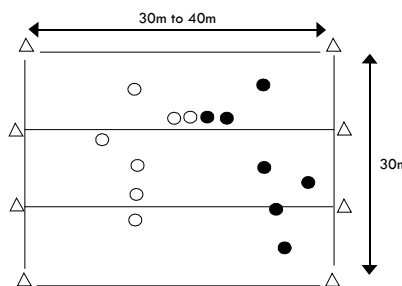

**Aim:** Defensive adjustment and communication attacking development of space creation.

**Equipment:** 8 markers (2 colours), 1 football, 12 to 16 players, tag belts if available.

**Set Up:** Playing area (using cross field markings) 30 metres wide by 30-40 metres long. Markers identifying "centre" or "double zone" area.

**Drill**

- Small sided game with rules as set by coach ie number of passes, allowable kicks etc.
- Outside thirds of field player 'tagged' by single player.
- 'Centre' third is the 'double-zone' where attacker must be tagged by two players (or both flags removed).
- Scoring can be adjusted ie 3 points between 'double zone' markers, 1 point outside thirds.

Defence



# SHUT DOWN

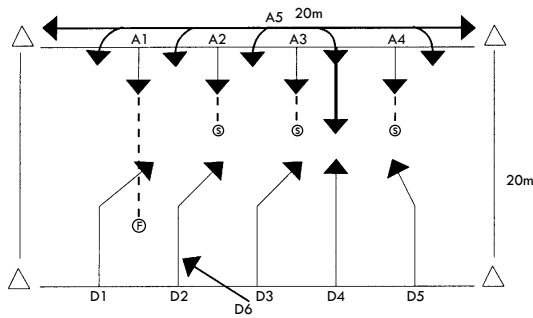

**Aim:** To develop vision and decision making skills of "middle" defensive players.

**Equipment:** 4 markers, 1 football, 9 to 15 players

**Set Up:** Set grid 20m x 10m. Place players at each end of grid with defenders having one extra.

### Drill

- One attacker(A5) jogs behind line carrying football
- On coaches signal (or players choice), he enters attack line and runs STRAIGHT.
- Other attackers move up straight in support
- Defenders must call BALL CARRIER with TWO players contacting ball carrier.
- Defenders D1 to D5 (after shutting down ball) must next shut down CLOSEST support.
- The FREE player (F) is shut down by cover defender.

Defence

# ONE ON ONE

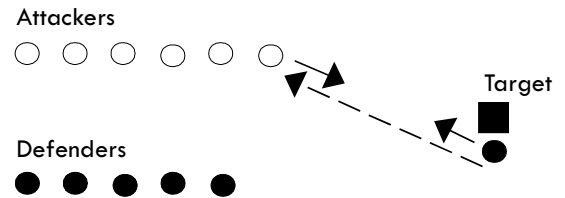

Divide players into two lines 6 metres apart, nominate one line as attackers and the other defenders, place a target (old T-shirt) midway between the lines.

The first defender comes forward with the ball and stands over the target. The defender passes the ball to the first attacker who must now score a try by placing the ball on the target.

The defender must tackle the attacker to stop the try being scored. The coach must emphasise that the defender must make and maintain solid upper body contact with the attacker. In all cases the defender must try to wrap up the ball and try to roll the attacker on his back to slow down the play the ball. The drill can be modified by changing the starting location of the defenders and attackers.

- The defender gains confidence by being in control of the drill, ie. the attacker must wait until the defender is ready and passes him the ball.

- The defenders quickly learn that they must move forward off their line to successfully defend the target.

Defence

# REACT & DEFEND

**Setting:** Three attackers (A) on three defenders (D), grid 15m x 15m

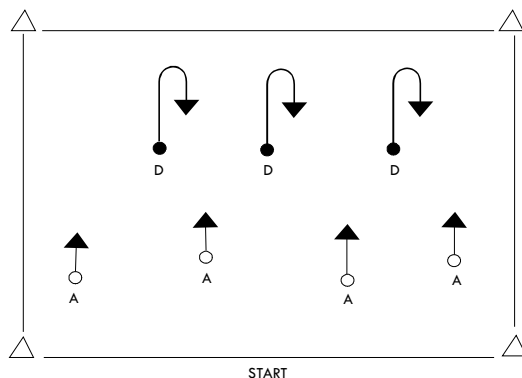

### DRILL

- Defenders jog down the grid
- Followed by attackers about 5m behind
- On coach's call defence turns and adjusts to the attack

Advance to multi tackle 3 on 3

Commence with 4D x 3A, 3D x 3A, 2D v 3A

Defence

# DEFENCE NOMINATION

**Setting:** Six attackers and five defenders. Each attacker has a hit pad, attackers in a line 5m away from the defenders.

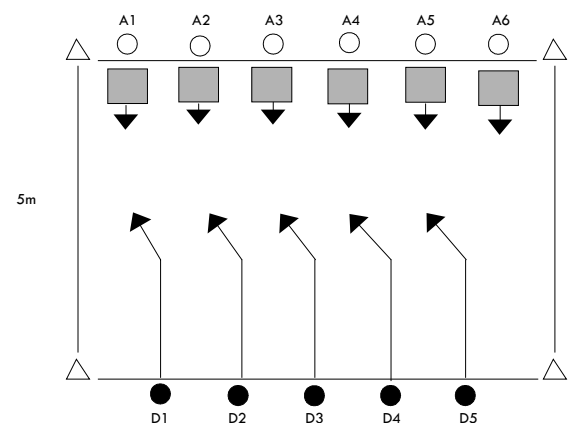

### DRILL

- Coach call left or right and the defenders move up in that direction, nominating by name the attacker they will engage.
- Players engage the pad then move back changing place with another defender on the way back.
- Emphasis nomination amongst defenders.
- On returning emphasise communication amongst defenders.

Defence

# FLOP

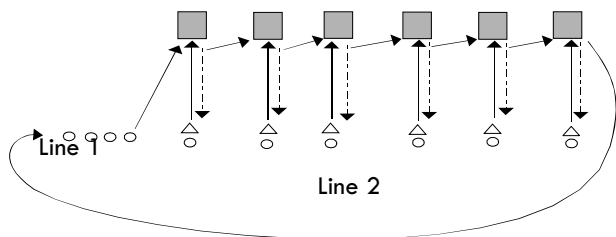

Tackler No.1 hits the bag low, whilst tackler No.2 is the second player and hits the bag chest high.

Players from line 1 will tackle 6 bags, whilst players from Line 2 will only tackle chest high on the allocated bag directly in front of them.

Defence

# CLOCKWISE TACKLING

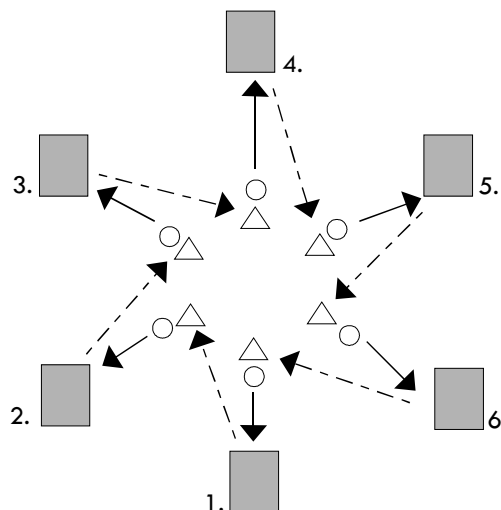

Tacklers position themselves in the centre of the drill, opposite a tackle bag. (As indicated)

Each of the players perform a tackle on the bag in front of them.

Players then run backwards to the centre of the drill, shuffling clockwise to position themselves in line with the next tackle bag, where they make the next tackle. The drill continues until all bags have been tackled.

Defence

# DEFENSIVE LINE POSITIONING

SETTING: Field Positions  
 GAME SKILLS: Organisation, Communication

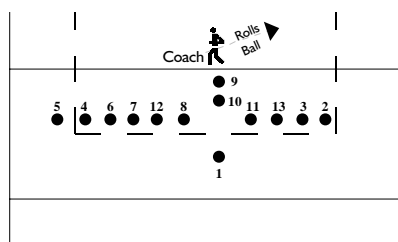

- Players line up as a team in their appropriate defensive line positions (diagram is simply a suggestion).
- Coach who starts with the ball rolls it anywhere on the field.
- The defensive line advances and the two nearest defenders drop on the ball.
- This represents a tackle.
- Meanwhile the rest of the defensive line should reposition themselves accordingly
- The fullback (1) should communicate with the line to ensure there are no obvious gaps.
- The ball is then given back to the coach in a new position and the sequence commences again.

N.B. Ensure that the coach varies the distance and angle of the roll.

Defence

# DEFENCE LINE COMMUNICATION

SETTING: Open space or suggested channel approx. 40m x 20m  
 4 to 6 players; 10 markers

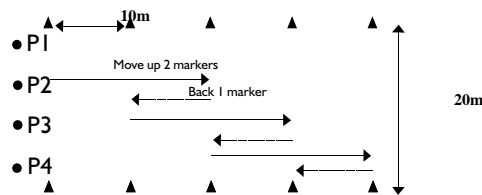

- 4 Players form a line at one end of channel.
- Players at end of channel move up 2 marker distances
- Then retreat back 1 marker by half turning to run back to line then turning to face front again.
- Drill continues length of channel. (ie up 2 back 1)

## OBJECTIVE

- Communication
- Working together
- Adjustment of defensive line
- Speed of the line
- Speed back to regroup line.

## (b) PROGRESSION

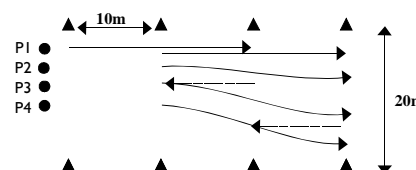

Similar to (a) except players alternate start on either left or right side of channel compressed together. As they move forward players spread out to cover the full width of the channel. As they move back they adjust to compress the defensive line before moving forward again.

Defence

**Rugby League Coaching Manuals (RLCM)**  
**PASSING KAMIKAZE DRILL**

**SETTING:** 4 Footballs, Groups of 4 players, 4 markers  
**GAME SKILLS:** Passing, Evasion, Vision, Communication

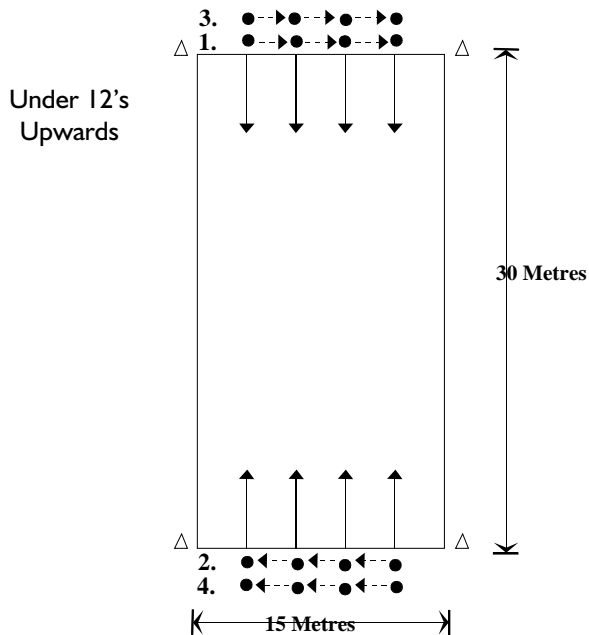

Teams 1 and 2 commence jogging and passing, on reaching the halfway mark, teams 3 and 4 commence. On approaching, teams will avoid each other but continue to pass as they run between the on-coming team.

Attack

**ZIG ZAG RELAY**

**SETTING:** Groups of 6 players  
 Distance will depend on age group  
 6 Markers, 1 Football  
**GAME SKILLS:** Handling, Passing, Running with the ball

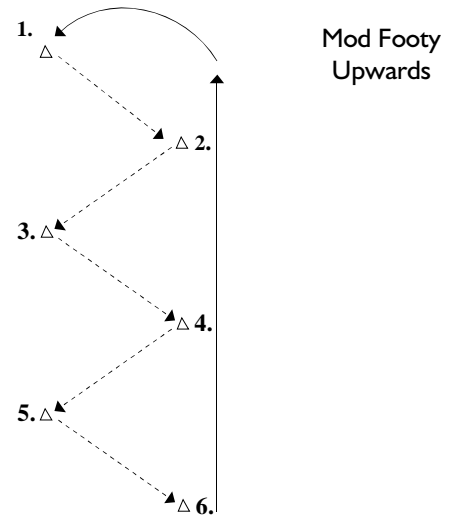

The ball starts at Position 1. The ball is passed in Zig Zag fashion to Position 6. The player at 6 in possession of the ball runs to Position 1 while all other players shuffle to the next station.

**VARIATION:** Player at Position 6 perform a Grubber or Chip kick while running to position 1.

Attack

**Rugby League Coaching Manuals (RLCM)**  
**2 ON 2 with ANGLE**

**Setting:** 15m x 20m, 5 markers, 8-16 players, 1 football

A number of options exist in this practice

- B runs across between D & C
- Depending on response of D & C
- A has the option to angle in or run the line
- B can present
  - (i) An outside pass to A
  - (ii) A can cut in on B & receive a close pass
  - (iii) A can angle behind C

**Rotation:** D to C, C to A, A to B, B to D

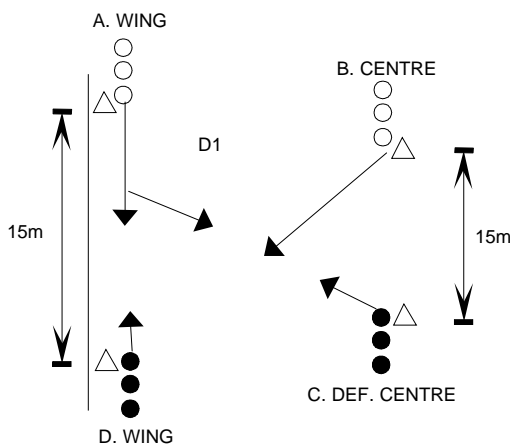

Attack

**3 ON 2 (A)**

**Setting:** - Grid 10 x 10m,  
 2 players are defenders, 3 are attackers.

- Players line up behind cones in three columns.
- On coaches command two nominated players sprint our around opposite cones and then become defenders.
- Next two players fill in the attacking line.
- The attacking line then attempts to beat the defenders with a 3 on 2 situation.

**EMPHASISE:** Communication (attack and defence), drawing the man, no silly passes, start slow

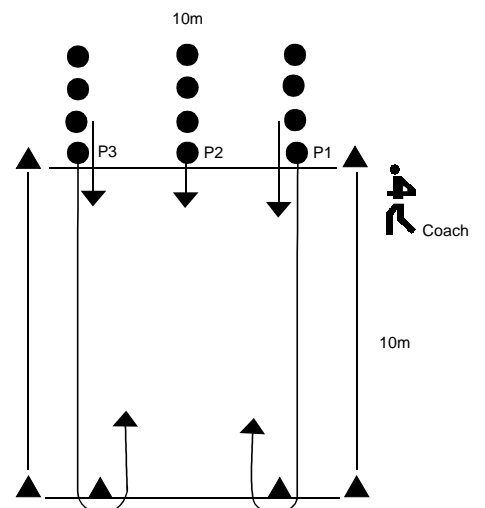

Attack

# 3 ON 2 (B)

- Setting: - Grid 10 x 10m,  
2 players are defenders, 3 are attackers.
- Players line up behind cones in columns of three as attackers and defenders at opposite ends of the grid
  - As attacking players move, coach commands one defender to stay out (nominate by name or number)
  - The attacking line then attempts to beat the defenders with a 3 on 2 situation.

EMPHASISE: Communication (attack and defence), decision making, drawing the man, no silly passes, start slow

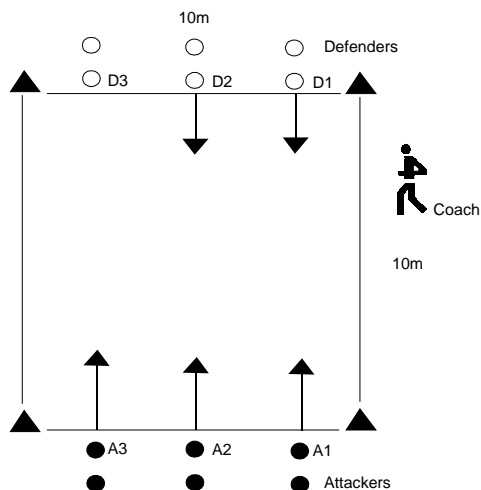

Attack

# FIND THE GAP

- 3 players using bump pads line up as indicated in the diagram
- A gap of between 1 and 2 metres is provided between 'tacklers" A and B, and B and C
- A fourth 'tackler", player D stands behind player B and moves across his own line to close one of the gaps as the ball carrier (P1) runs towards tackler B
- Support players P2 and P3 receive a short pass from the ball carrier who has created a gap for these players by drawing the tacklers.
- Tackler D attempts to stop the movement by closing the gap created by the ball carrier.

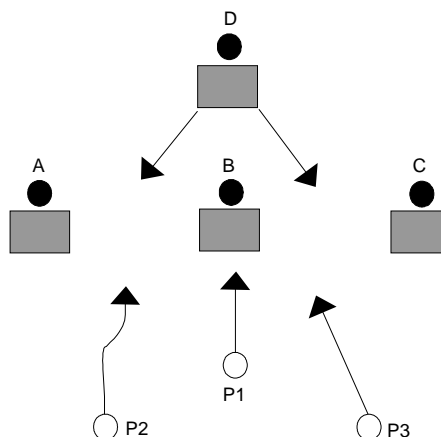

Attack

# ROTATION

- Setting: - Players form two circles  
- Two players stand inside circles
- Players in the inside circle run one way whilst players in the outside circle run in the opposite direction.
  - Two players in the middle make a pass:
    - To the players in the outside circle
    - Alternately to the inside and outside circle
    - To players in the outside circle with players in the inside circle attempting to knock down the passes

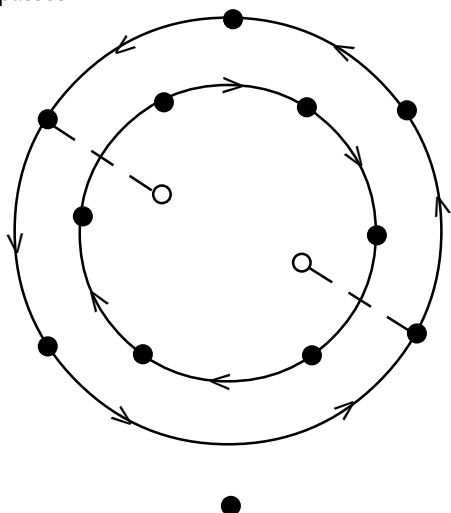

Attack

# ARROWHEAD

- Setting: - Two equal lines of players aligned at right angles
- Team 1 commences the drill, running straight.
  - Team one commences passing the ball at speed along their line.
  - After releasing the ball each player runs backwards to their starting position.
  - Player 1E off loads to player A in team 2.
  - Team 2 then speed passes, following the same procedure as Team 1.

Note

- Player 1E holds the position of 2A waiting for the next run, likewise player 2E holds the original position of 1A.

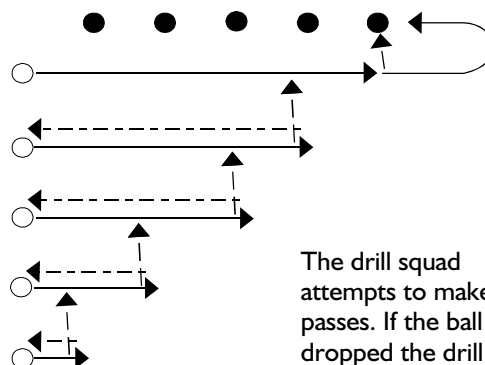

The drill squad attempts to make 100 passes. If the ball is dropped the drill recommences.

Attack

# KICK AND PASS

- Setting:
- Grid 20m x 20m
  - 2 equal teams of players
  - 1 football

- One team is given the ball and attempts to keep possession for up to 10 passes or kicks.
- Every set completed gains a point
- The opposing team attempts to intercept or knock the ball down, gaining possession when it interrupts the other team's set.
- Player in possession may move around grid looking for best option.

Emphasise: One handed pass, fending and passing, passing under pressure, grubber kicks, chip kicks.

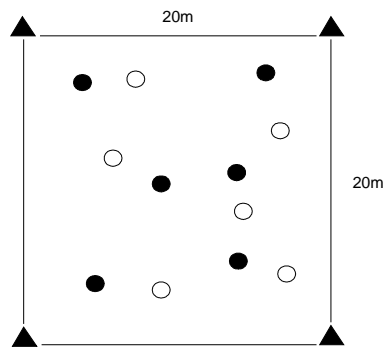

Attack

# AGILITY POLES

- Coach stands 5m in front of players holding pole.
- As players run towards the pole the coach leans it either to the left or right.
- Player then swerves to the opposite side of pole and runs around coach.

## PROGRESSION

- Add a second pole wide of the first
- P1 runs to the side the pole is leant
- P1 then passes a flat pass to P2 who must swerve to the left or right of his opposite pole.

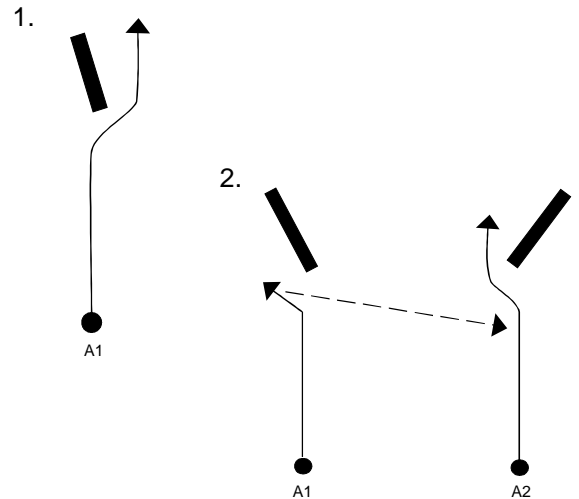

Attack

# ANGLES

- Setting: Grid 10m x 10m, 4 markers, 8-16 players, 1 football for each A player

- A runs out and cuts across the grid to draw D so that D cannot take S
- S moves out on a straight line, angles back to cut in behind A1.
- S times his run to occur when A has drawn D and runs as close to A as possible without being tackled by D

Rotation: S to A,  
A to D,  
D to S

Progression:  
Defender stands opposite, slightly inside of S

Rotation:  
A to D2, D2 to S, S to D1, D1 to A

Attack

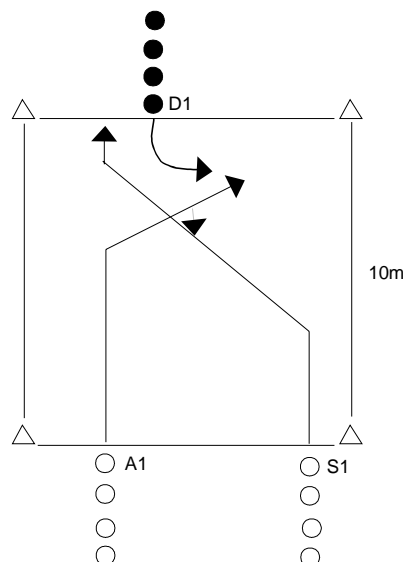

# ATTACK DEVELOPMENT "OVERS"

- Setting: Grid 15m x 15m, 4 markers, 6-12 players, 1-3 footballs

- A1 runs curve line to D1 cutting across or over D1 drawing D2
- A2 runs a wide line in support of A1 holding his line to stay outside of D2

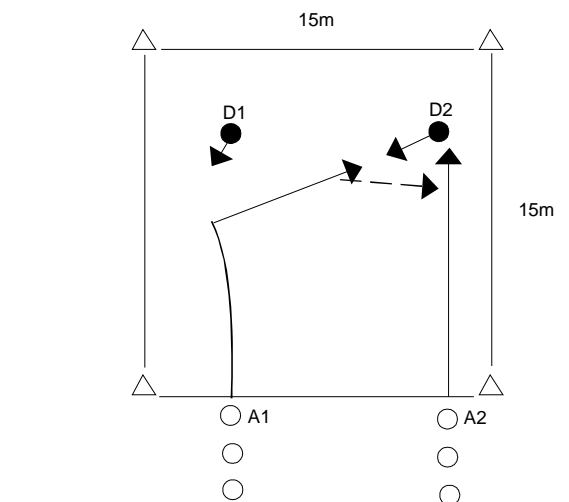

Progression: 3A v 3D

Attack

# ATTACK DEVELOPMENT "UNDERS"

Setting: Grid 15m x 15m, 4 markers, 6-12 players, 1-3 footballs

- A1 runs line to D1 inside shoulder drawing D1 and passing to A2
- A2 runs a wide line in support of A1 holding D2.
- When A1 sets to pass A2 cuts "under" D2 into hole.

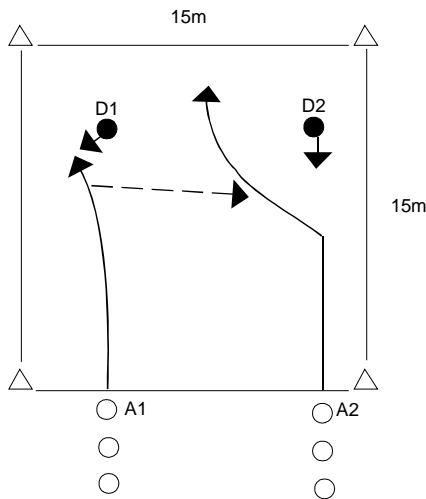

Progression: 3A v 3D

Attack

# THREE ON THREE (UNDERS)

Setting: 4 Markers - 20m x 15m grid  
9 players per grid - 3 as defenders  
3 spin pads (optional)

Attacker (A) and support players move to defenders with attacker (A) drawing first defender (D) away from the support players (S1) who times his changing angle run into space receiving an on-side pass 'under' his defender (D1). S1 draws D1 then passes to S2, who has held his opposite player D2, inside by running a line on D2's outside shoulder, before timing his change of angle into space.

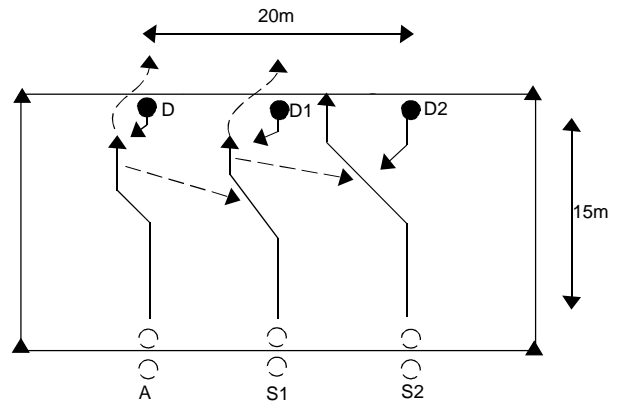

Attack

# THREE ON THREE (SWITCH OVER)

Setting: 4 Markers - 20m x 15m grid  
9 players - 3 as defenders  
3 spin pads (optional)

Attacker and support players move to defenders. Attacker (A) 'draws' Defender (D) and passes 'under' to support player (S1) who has changed his angle to run under his nominating defender (D1). Once in possession of the football, (S1) changes angle to run 'over' and across his defender (D1) into space and to draw (D2). Support player (S2) receives a pass from (S1) and runs in space on the outside left vacant by the defender (D2).

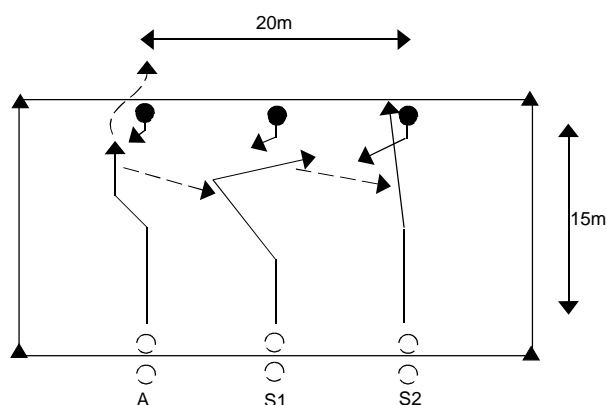

Attack

# SPONTANEOUS SUPPORT

Setting: Grid 10x 35m, 6 markers, 4 pads, 8 players, 1 football

- A players commence with the ball and attempt to break through the 2 defence padmen who can only move laterally.
- D1 cover defends across the grid but only after A breaks the first line.
- The second cover defender, D2, moves into the grid to cover after the A has beaten D1.
- D3, the full-back, moves in to defend after A passes D2.
- Beaten defensive players sprint to base line (by running outside grid)

D1 and D2 can finish their tackles

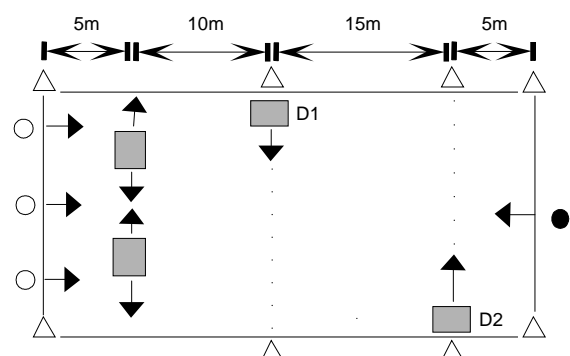

Attack

# SWERVE RELAY

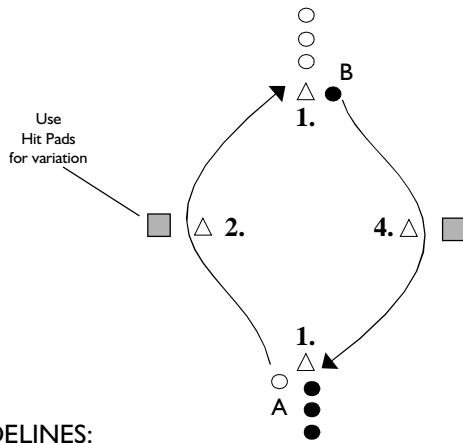

**GUIDELINES:**

- Player A starts running from marker 1 around marker 2 and handing off to player B at marker 3.
- Player B repeats the exercise in the opposite direction rounding marker 4 and handing off to player C at marker 1.
- Once a player has run they must return to the end of the line.
- The drill can be run as a relay race between two teams competing on different courses.
- The cycle is reversed regularly to ensure right and left swerves are developed.
- Keep drill as small as possible to reflect a game situation.

**VARIATION** Hits pads on markers 2 and 4 to apply running pressure and promote running balance.

Attack

# SIDE STEP (TECHNIQUE)

**GAME SKILLS:**

- Sidestep
- Speed
- Hand Off Pass

**GUIDELINES:**

- Set up two sets of markers per diagram, with approximately 6 players per team, with 3 at each end.
- On a signal, the players with a ball run to the first marker and sidestep to run to the second dome where they step again, either foot
- Players step again at the last marker and hand off the ball to the next player and so on until the relay is completed.

**NOTE**

- Many players will attempt to shuffle around markers rather than step. Keep correcting.
- Young players may need to start with a simpler version to assure correct technique.

Attack

# HIT and SPIN

**SETTING:** Open space  
2 Markers  
1 Bump shield (Hit pad)  
1 Football

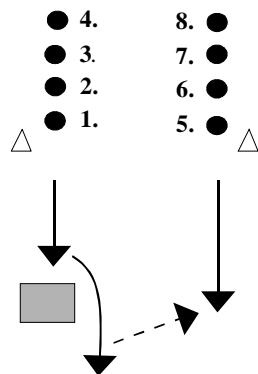

**PASSING PAIRS**

No 1 runs with the ball in both hands and bursts onto the shield that is held at waist height by another player.

He hits, spins and passes to support that has come with him on left. both players then retire behind their respective lines.

Another pair of lines are set up similarly but pass in the opposite direction.

Attack

# 2 on 1 EVASION

**SETTING:** Grid 10m X 10m  
3 Players

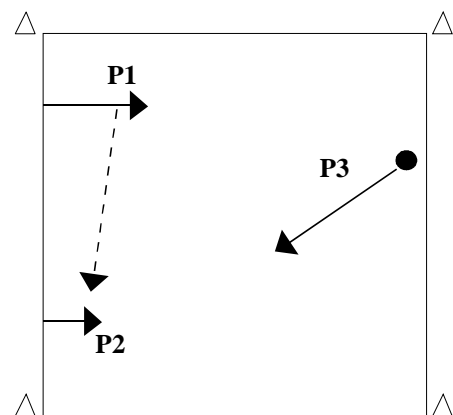

Three players to a grid 10m x 10m. player 1 passes to 2 with plenty of room to move and he attempts to beat 3 with a fend, swerve, side-step or change of pace. 3 attempts to tackle him although he is not allowed to start defending until the ball has left player 1's hands.

N.B. While player 2 gets the ball early, player 3 must wait for the ball to leave player 1's hands before moving.

Attack

# ATTACKING FROM SCRUMS

## 1. USING AN EXTRA PLAYER

The players introduced into the line most frequently are:

- (a) the fullback
- (b) A blind side attacker
- (c) The loose forward

### (a) THE FULLBACK

He is able to time his run and select any option, and can join the line to the open side or blind, and in between any of the players. The art of a good attacking fullback is to arrive in a space before his opposite number. The fullback enters the line between the five eight and inside centre. Alternatives are to (i) enter the line in a catch-pass situation and create extra men out wide, or (ii) be used as a decoy. It is important for the blind side winger to cover behind from a scrummage.

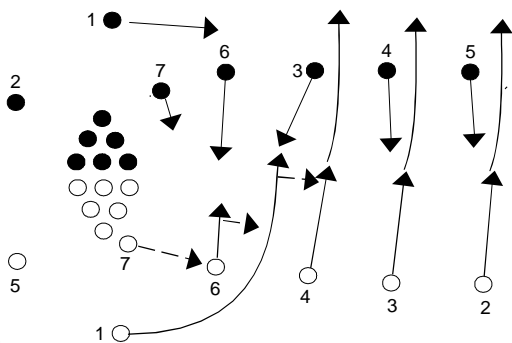

Attack

# ATTACKING FROM SCRUMS

## 1. USING AN EXTRA PLAYER

### (b) THE SHORT SIDE ATTACKER

An extra man can be introduced into the line by using a winger or centre from behind the blindside. The extra man can either loop round and try to break the line himself, or join the line early and try to create the gap for someone else.

- (i) The blind winger, A5 times his run, and arcs off the inside centre breaking the line himself.

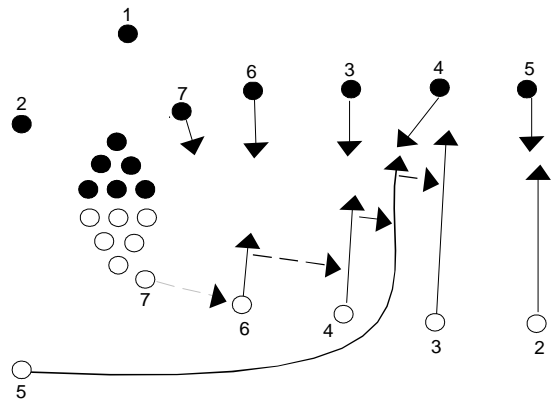

Attack

# ATTACKING FROM SCRUMS

## 1. USING AN EXTRA PLAYER

### (b) THE SHORT SIDE ATTACKER (continued)

- (ii) The blind side centre, A3, receives the ball on the open side from the scrum half. By slick handling the open side winger, A5, is given an overlap.

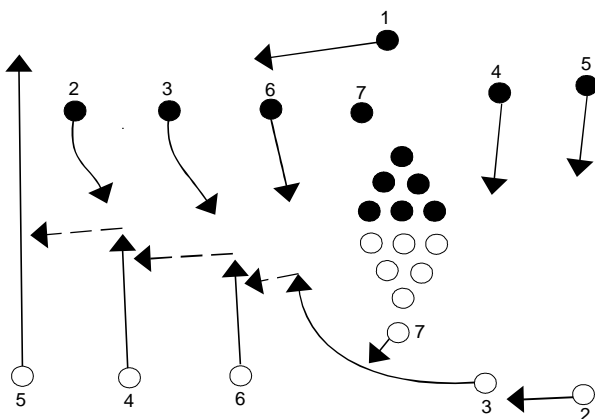

Attack

# ATTACKING FROM SCRUMS

## 1. USING AN EXTRA PLAYER

### (c) THE LOCK FORWARD

The loose forward is perhaps the only other player who can enter the line from a scrummage and create an extra man.

The scrum half carries the ball forward, and of loads to the loose forward on his inside, after first committing the defence.

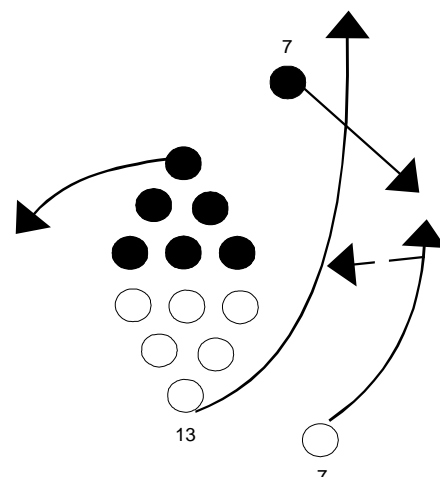

Attack



# ATTACKING FROM SCRUMS

## 2. USING A PLAYER TWICE

The five eight (A6) runs around both centres, while the fullback runs as a decoy between them. The aim is to move the ball wide to the five eight in space, after having brought the defensive full back into the line. The blind side winger covers for the full back

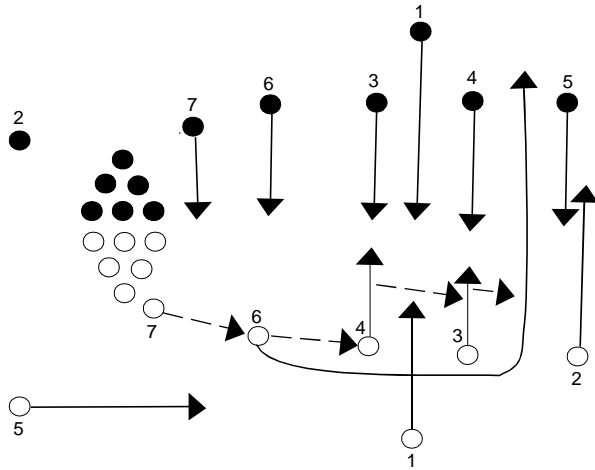

Attack

# ATTACKING FROM SCRUMS

## 3. CHANGING ANGLE OF ATTACK

Ball is quickly passed to the inside centre (A4) via the half back (A7) and five eight. He runs at speed across field towards outside centre, (D4), taking inside centre (D3) with him.

Both centres are drawn towards A4 who makes a drop off pass to (A3).

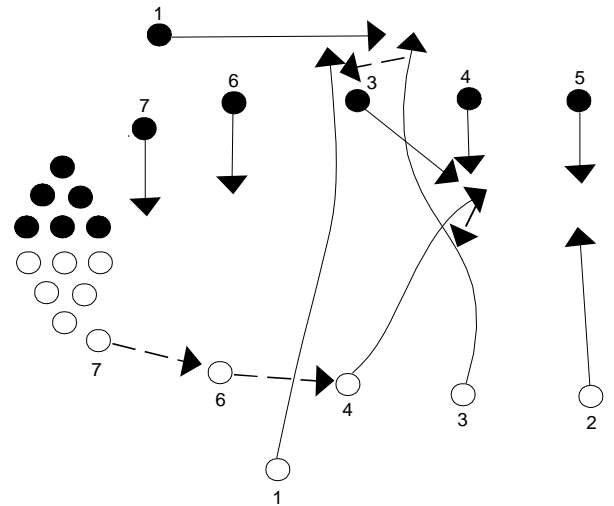

Attack

# ATTACKING FROM SCRUMS

## 4. A KICK

It is policy with some teams defending from a scrum to position their fullback in the defensive line.

When this occurs the defenders have no last line of defence and are susceptible to a kick either through or over them. A1 stands in the line from the scrum, between A6 and A4. D1, moves up into his defensive line to mark him. On winning the scrum, A7 passes to A6, who carries the ball towards the opposition, committing them, but before being tackled chips over their heads.

The rest of the team are onside, and chase the ball.

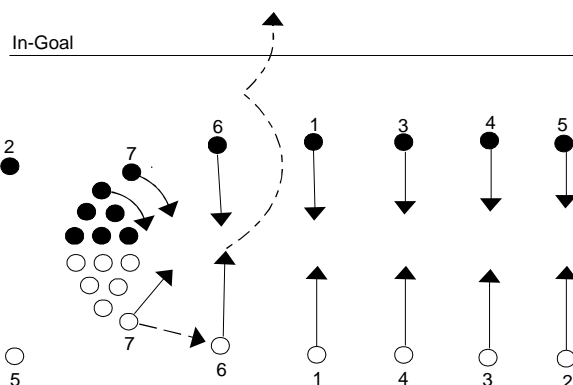

Attack

# ATTACKING FROM SCRUMS

## 5. FIRST TACKLE FORWARD RUSH

A back row which breaks quickly from a scrum can often attack from the first play the ball, before the opposition arrives.

From the scrum, the five eight (A6) takes the ball hard into his opposite number. Once tackled he plays the ball as quickly as possible. The scrum half moves into acting half back, while the back three forwards (11, 12 and 13) loop around and attack on the first play.

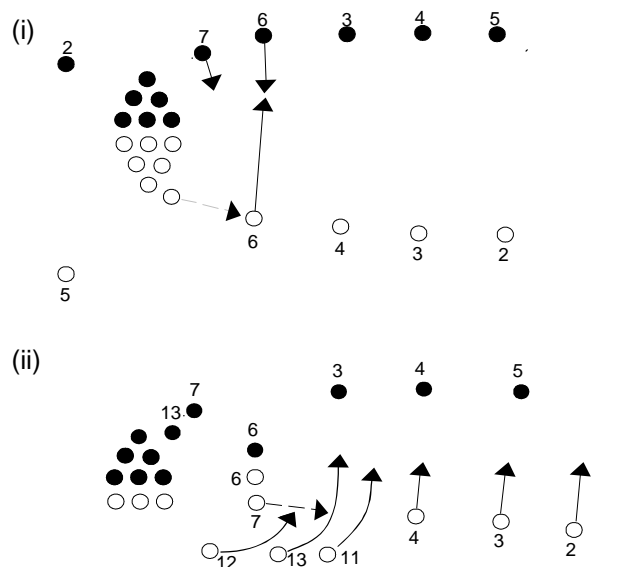

Attack

# ***rlcm.com.au***

The publishers wish to thank the Australian Rugby League and contributors for their assistance in compiling this publication.

## **Queensland**

Suite 1F, Trust House  
3070 Gold Coast Hwy  
Surfers Paradise  
QLD AUST. 4217

PO Box 259,  
Surfers Paradise  
QLD AUST. 4217  
Ph: (07) 5538 9377  
Fax: (07) 5538 9388

## **New South Wales**

Suite 111  
353 King Street  
Newtown  
NSW AUST. 2042

Locked Bag 18/111  
Newtown  
NSW AUST. 2042  
Ph: 1800 18 14 14  
Fax: 1800 18 14 15

## **UNITED KINGDOM**

The Conifers, 1 New Lane,  
Skelmanthorpe,  
Huddersfield  
West Yorkshire  
UK HD8 9EH  
Email: [england@rlcm.com.au](mailto:england@rlcm.com.au)

## **NEW ZEALAND**

132 Victoria Road,  
St Kilda, Dunedin,  
New Zealand  
Fax (03) 456 3498,  
Email: [rlcm@ihug.co.nz](mailto:rlcm@ihug.co.nz)

### **Publisher**

Gary Roberts  
[rlcm@rlcm.com.au](mailto:rlcm@rlcm.com.au)

### **Production**

Reagan Roberts  
[reaganr@ozemail.com.au](mailto:reaganr@ozemail.com.au)

### **Research**

Keith Hookway  
[keith@rlcm.com.au](mailto:keith@rlcm.com.au)

### **Editor**

Terry Prindable  
[editorial@rlcm.com.au](mailto:editorial@rlcm.com.au)

Endorsed By



## **DISCLAIMER**

The information in this publication is given in good faith and has been derived from sources believed to be reliable and accurate. However, neither Shamrock Books, nor any person involved in the preparation of this publication accept any form of liability whatsoever for its contents including advertisements, editorials, opinions, advice or information or for any consequence for its use.

**No part of this publication may be reproduced, stored in any retrieval system, or transmitted in any form or by any means electronic, mechanical, photocopying, recording or ink-jet printing without prior written permission of the publishers.**

Published by Senior Scene Pty Ltd  
T/A Shamrock School Books  
ABN 82 050 409 268

Rugby League Coaching Manuals  
ISSN 1446-3628